

Delta What?

An Update on Novel Cannabinoids

Dr. JoAn Laes

Allina Health, Minneapolis, MN

Dr. Robert Cole Pueringer

Essentia Health, Duluth, MN

Dr. Evan Schwarz

UCLA Department of Emergency Medicine, Los Angeles, CA

Dr. Alaina Steck

Emory University Department of Emergency Medicine, Atlanta, GA



Disclosure Information

- ◆ Dr. JoAn Laes
No disclosures
- ◆ Dr. Robert Cole Pueringer
No disclosures
- ◆ Dr. Evan Schwarz
No disclosures
- ◆ Dr. Alaina Steck
No disclosures

Learning Objectives

By the end of this session, attendees will be able to:

1. Describe the evolution of cannabis products in the U.S., including delta-8 THC and other novel / minor cannabinoids.
2. Understand the differences in clinical effects, potential for harm, and laboratory testing strategies related to the consumption of novel cannabinoids as compared to more traditional cannabis preparations.
3. Appreciate the societal implications and medico-legal aspects of using novel /minor cannabinoid products.

OGDEN, UTAH, SATURDAY, SEPTEMBER 25, 1915.

“... the marihuana is more deadly today than it was in the [1870’s], for the Mexicans now are using it in cigarettes, and with each cigarette the desire to take the United States and annex it to Mexico seems to become stronger. And so the victims of the drug sleep on with their minds wandering far into the regions of the impossible, for its [sic] marihuana after all—and not real nerve and courage—that seems to be behind Mexico.”

— *The Ogden (Utah) Standard, September 25, 1915*

Accounted For In the Familiar
Historical Legend Of the
Poisoned Tea

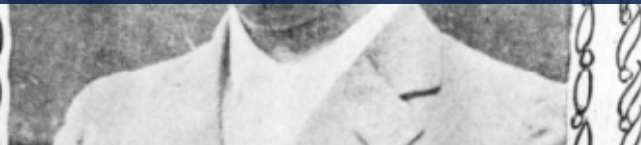



What is Cannabis?

Image credit: <https://www.fieldlaw.com/Industries/Cannabis>



Cannabis sativa
Cannabis indica
Cannabis ruderalis



more than

600 identified
chemicals

120 cannabinoids

native form
in plant

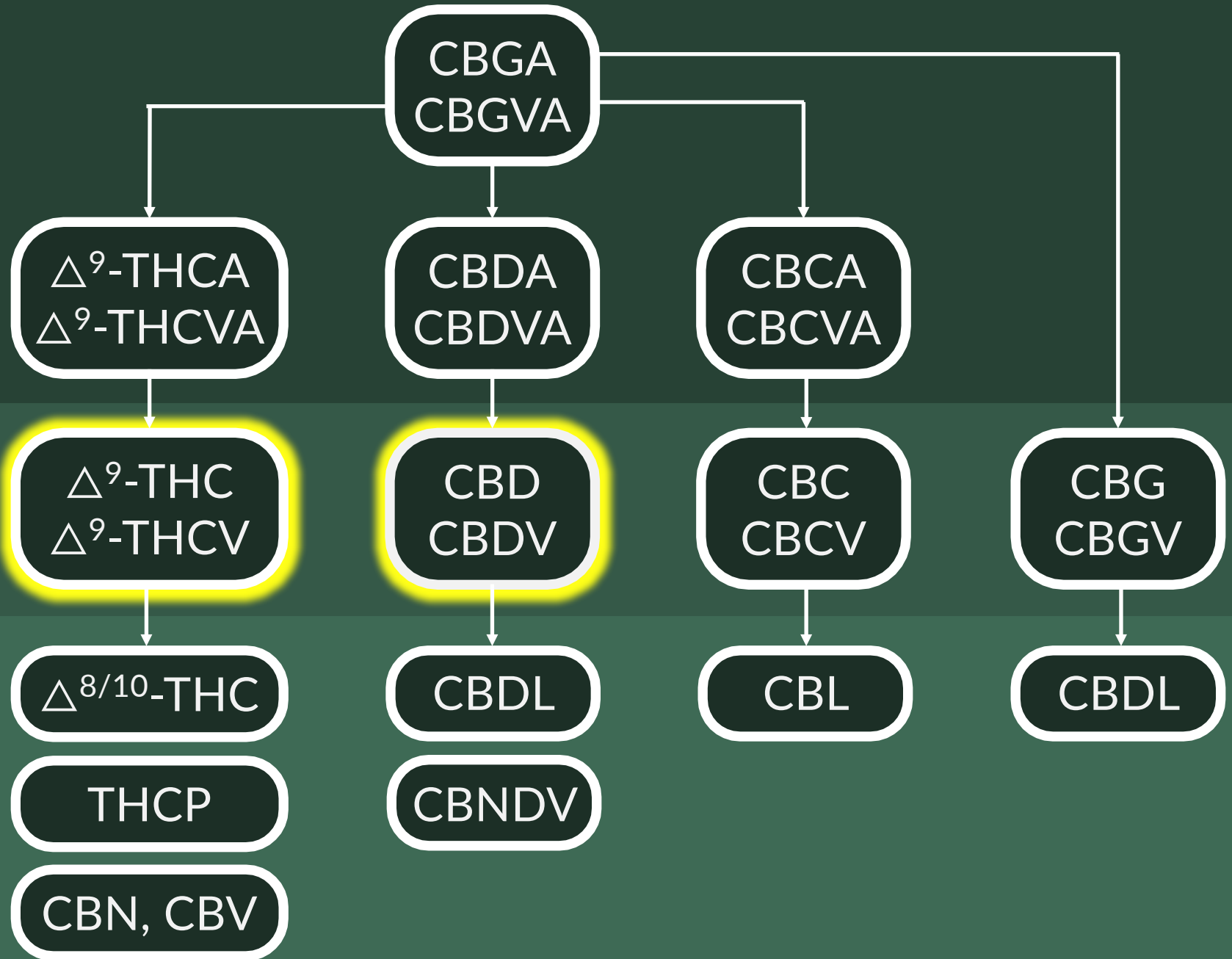

heated

degradation /
chemical
manipulation

native form
in plant

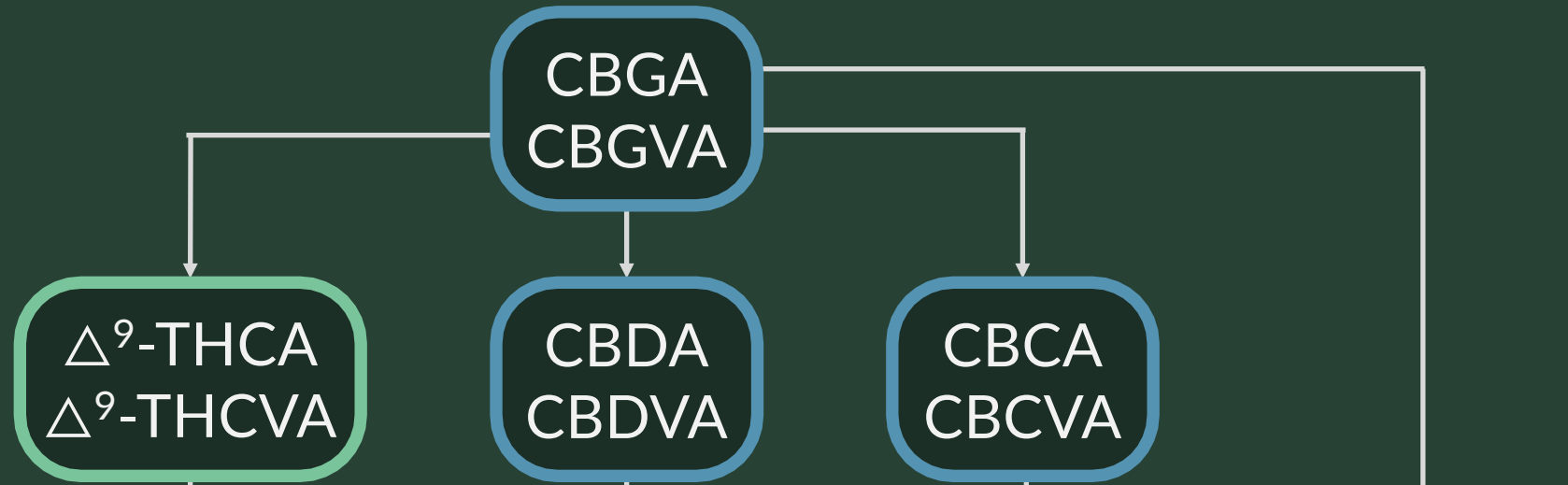

heated



degradation /
chemical
manipulation

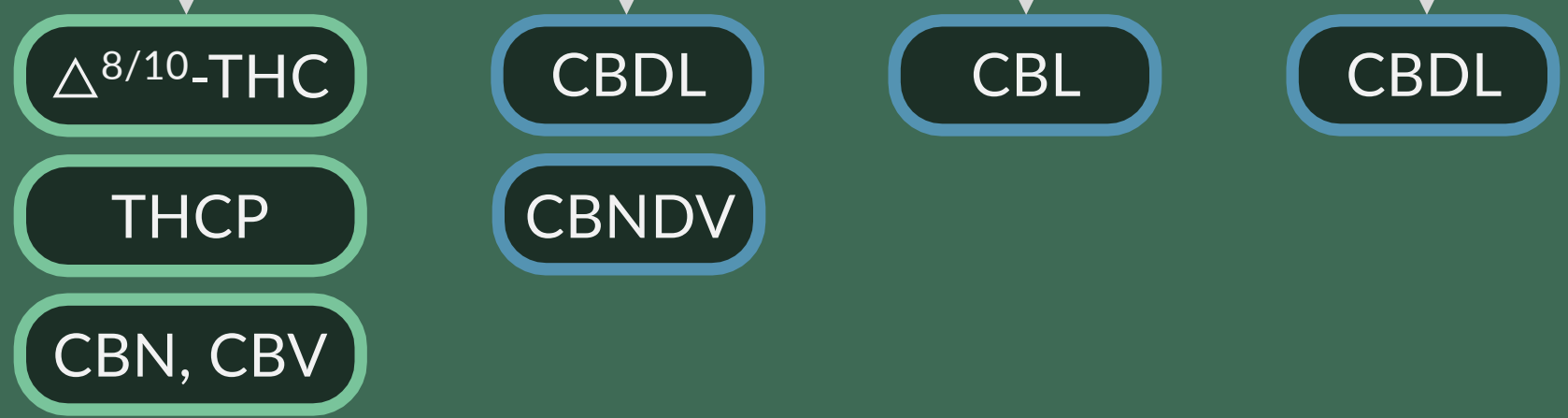

Endogenous Cannabinoids: MoA

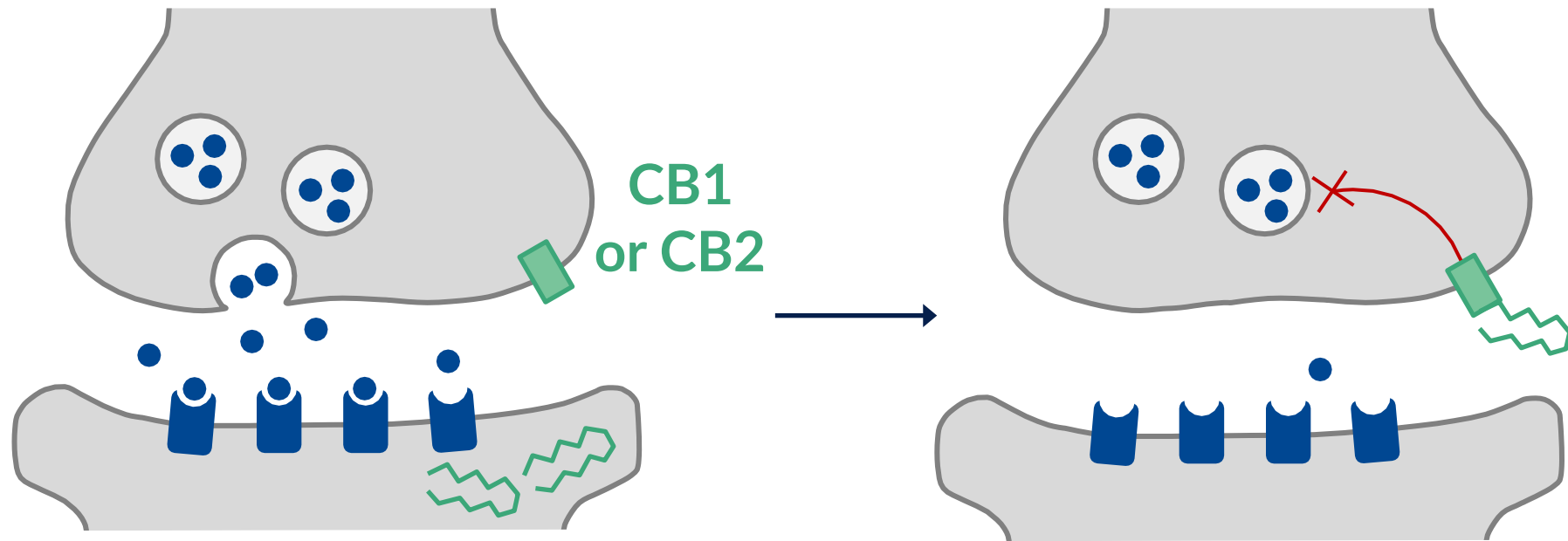

CB1 and CB2 Receptor Distribution

CB1: CNS

- cortex: cognition, *psychoactive effects*
- hippocampus: memory
- basal ganglia, cerebellum: motor function
- ascending / descending SC: nociception
- medulla: nausea / vomiting
- nucleus accumbens: reward

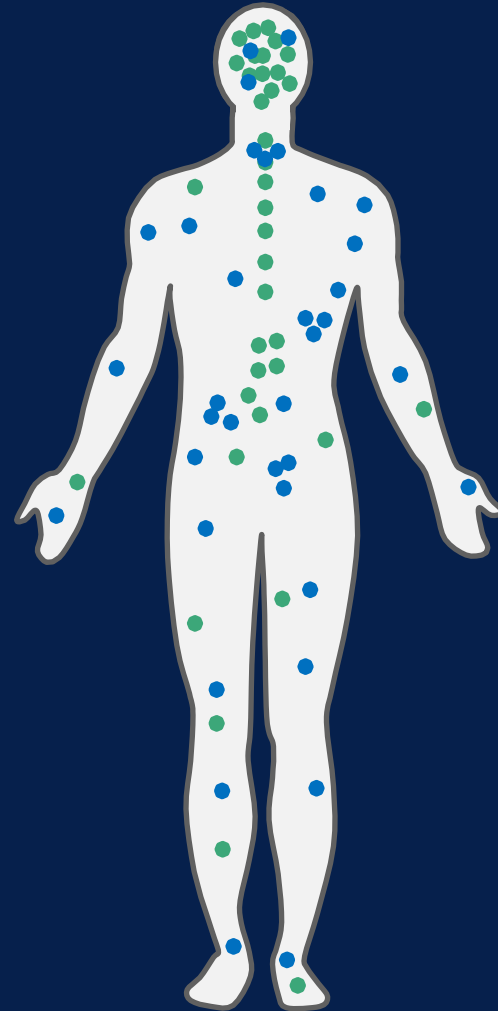

CB2: periphery

- thymus, spleen: ?
- NK and B cells: ?
inflammatory response,
? chronic pain processes
- gut: ?
- kidney: ?
- pancreas: ?
- adipose: ?
- eye: ?

Agenda

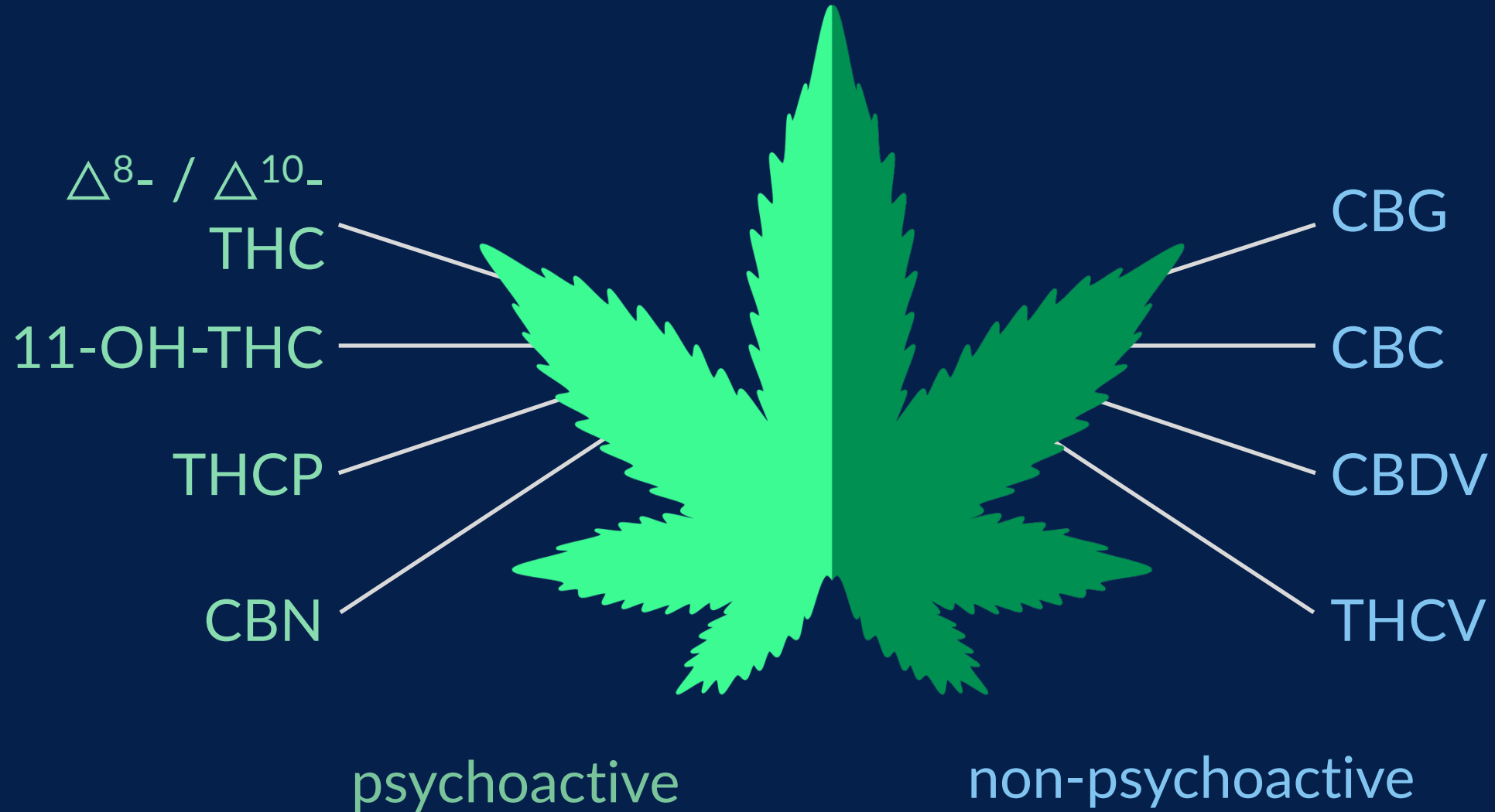

Agenda

Δ^8/Δ^{10} -THC

11-OH-THC

THCP

CBN

CBG

CBC

CBDV

THCV

psychoactive

non-psychoactive

Delta What?

DELTA-8 THC | THE BASICS

WHAT is Delta-8 THC?

- A cannabinoid, existing naturally in hemp, in small concentrations
- Chemically similar to CBD and D9-THC (found in marijuana)
- Abbreviated as D8-THC, DB, Δ8-THC, Δ8-THC
- Became federally legal with an amendment to the 2018 Farm Bill
- Strong indications of significant health benefits
- Creates a mental high of euphoria with fewer side effects than D9-THC

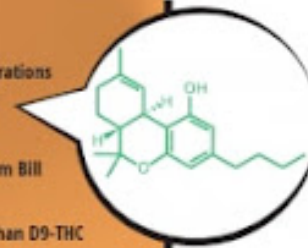

HOW is Delta-8 Made?



POSITIVE EFFECTS

- A Focused, Mental High, without paranoia
- Mood Boost, Euphoria
- Reduced Anxiety
- Pain Relief
- Appetite Increase
- Other effects by strain (indica, Sativa, Hybrid)

	Delta-8	Delta-9	CBD
U.S. Federally Legal	YES	NO	YES
States Legal	Most	Some	Almost All
Provide a Mental High	YES	YES	NO
Health Benefits	YES	YES	YES
Paranoia or Anxious Side-Effects	NO	YES	NO

Is Delta-8 THC Legal?*



- Will I Pass a Drug Test? - NO
- Will I Reap the Health Benefits? - YES
- Will I Feel Euphoric? -YES

*Federally Legal with some varying state laws



Δ^9 -THC vs Δ^8 -THC

DELTA-9-TETRAHYDROCANNABINOL VS DELTA-8-TETRAHYDROCANNABINOL MEDICAL APPLICATIONS

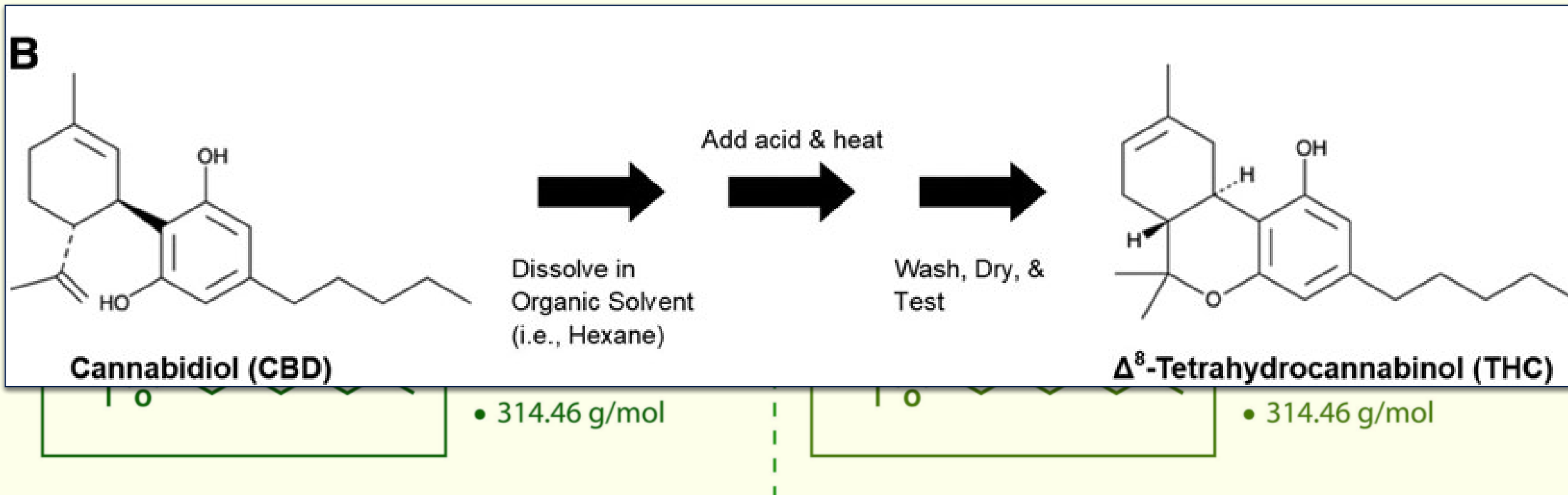

Hemp v. Marijuana

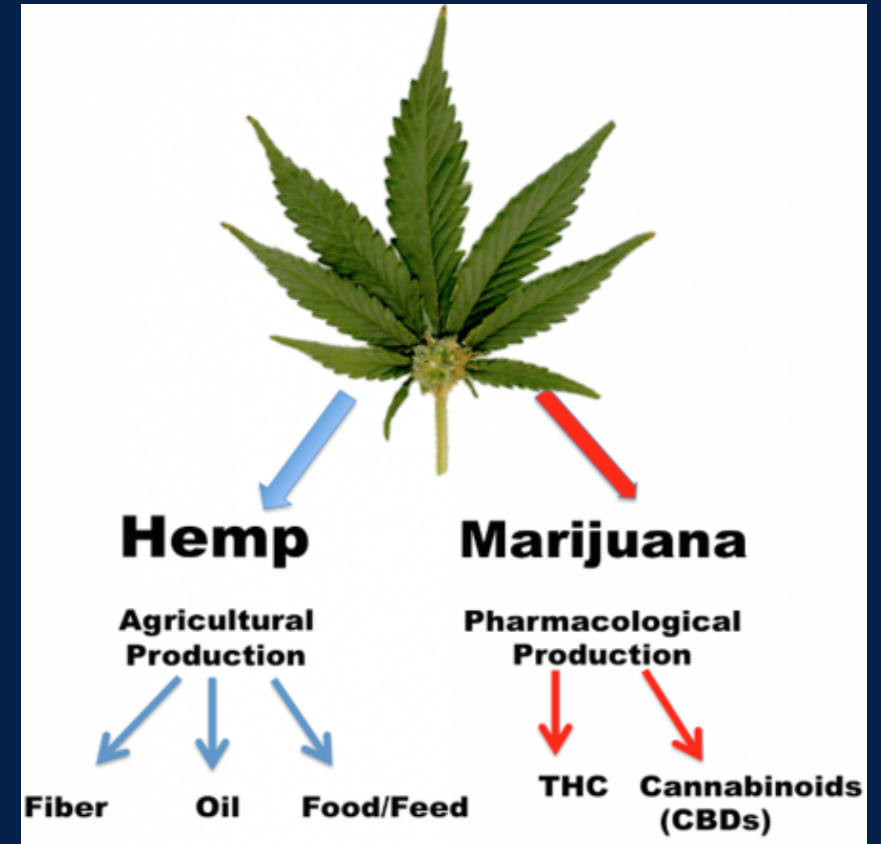

Legal Challenges of Delta-8-THC



FDA NEWS RELEASE

FDA Issues Warning Letters to Companies Illegally Selling CBD and Delta-8 THC Products

Violations Include Marketing Unapproved New Drugs, Misbranding, Adding Delta-8 THC to Food Products

‘CBD and delta-8 THC are unapproved food additives for use in any human or animal food product...’

For Immediate Release: May 04, 2022



Legal Challenges of Delta-8-THC

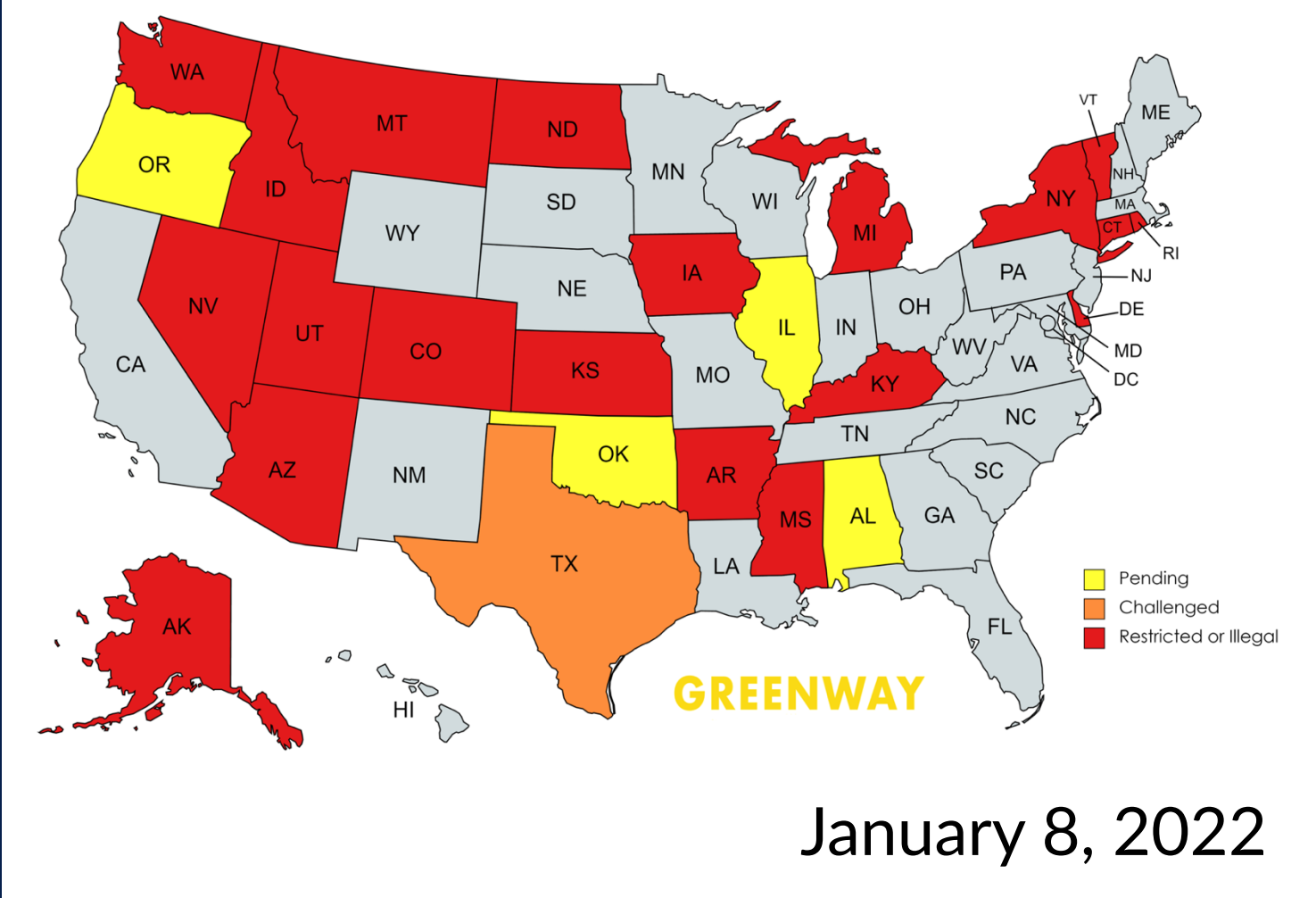

Legal Challenges of Delta-8-THC

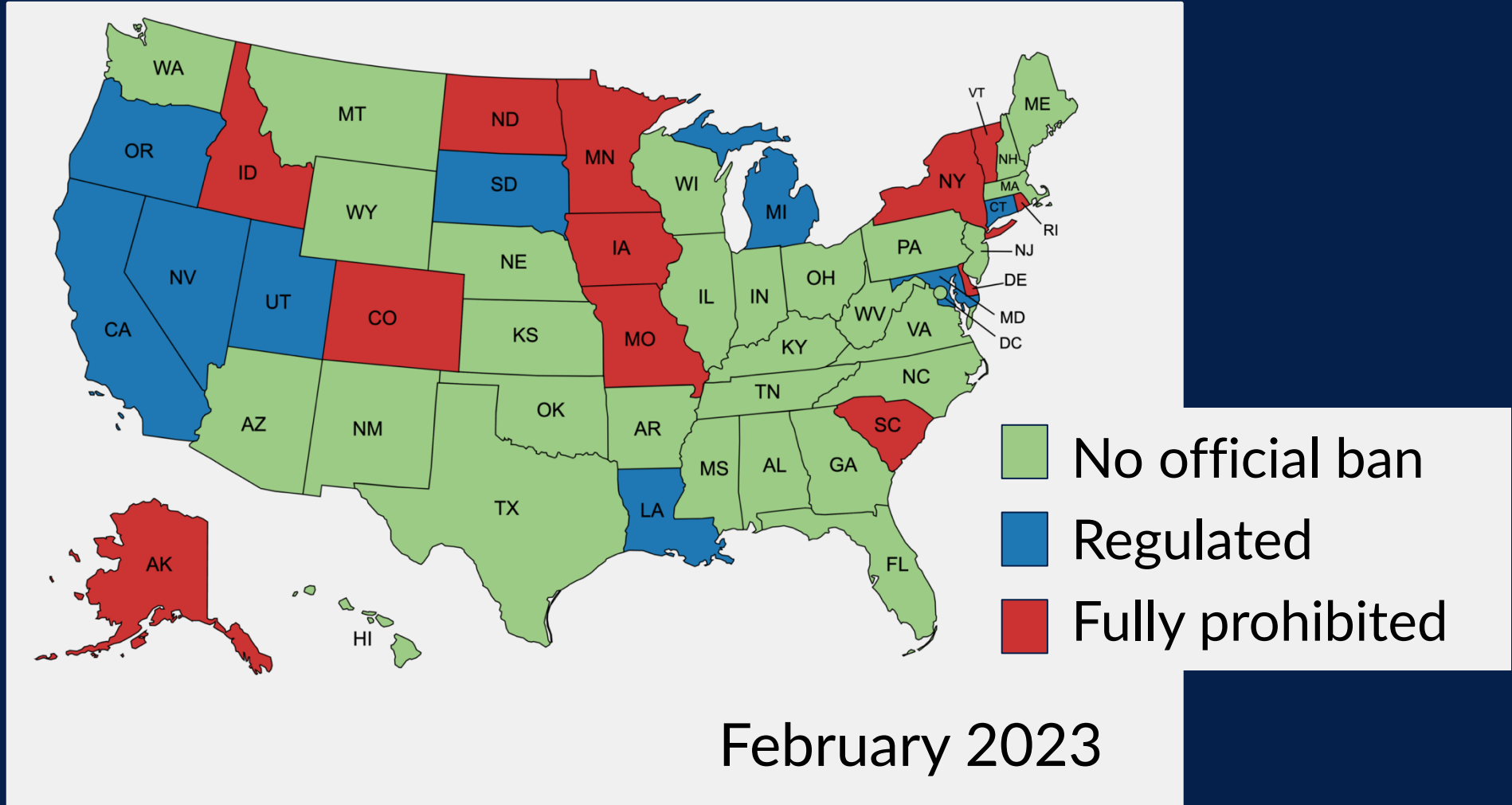

Clear as Mud?

‘Do not produce or sell delta-8 products without a permit to produce or sell THC as a controlled substance...The correct path for the legal production and sale of delta-8 products is through a state-licensed adult recreational or medical marijuana operator.’

-Marielle Weintraub, Ph.D., US Hemp

A 3 judge panel for the 9th Circuit Court of Appeal rejected arguments that Delta-8 products synthetically derived from hemp are not legal or protected under the 2018 Farm Bill.

The ruling does not deem delta-8 legal or protected across the US, just in 9 jurisdictions....



Authority

So What's the Deal with Them?

Metrics	HHC	Delta-8
Psychoactivity	Moderate-High	Mild-Moderate
Cost	\$\$	\$\$
Concentration in cannabis	Less than 0.1%	Less than 1%
Receptors	CB1 & CB2	CB1 & CB2
Typical dose	10-30 mg	10-40 mg
Effects on appetite	Weak stimulant	Strong stimulant
Anxiety side effects	Very mild	Very mild
Legality	Legal gray area	Legal gray area
Shelf-Life	Very long (5+ years)	Moderate (3-5 years)

What is DELTA-8?

Delta-8 is a form of THC, which shares a fair number of similarities with the more popular variation, Delta-9. Delta-8-tetrahydrocannabinol, or delta-8 THC, is substantially less potent than the standard delta-9 THC. Because these two compounds bind in a slightly different fashion, the potency of the high is affected. So, delta-8 causes a less intense high, compared to standard delta-9 THC.

The Effects of Delta-8



Anxiolytic
Relieves anxiety

Neuroprotectant
Recovers and regenerates nervous system



Antiemetic
Anti-nausea

Appetite Stimulant
Increases hunger



Analgesic
Relieves pain

Anti-Inflammatory
Reduces inflammation

 **KIND MEDS**

Δ^8 -THC vs Δ^9 -THC



DELTA-8-TETRAHYDROCANNABINOL VS DELTA-9-TETRAHYDROCANNABINOL MEDICAL APPLICATIONS

Δ^8 -THC

Delta-8-Tetrahydrocannabinol

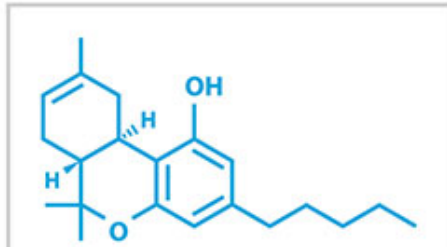

Chemical Formula

$C_{21}H_{30}O_2$

$C_{21}H_{30}O_2$

Molecular Weight

314.46 g/mol

314.46 g/mol

Anticancer

Analgesic

Antiemetic

Antiemetic

Anxiolytic

Anti-inflammatory

Appetite Stimulant

Appetite Stimulant

Δ^9 -THC

Delta-9-Tetrahydrocannabinol

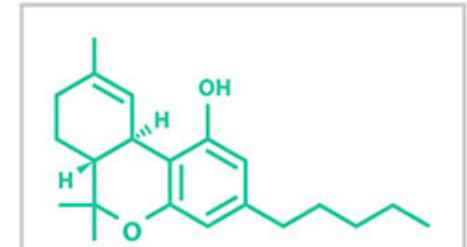

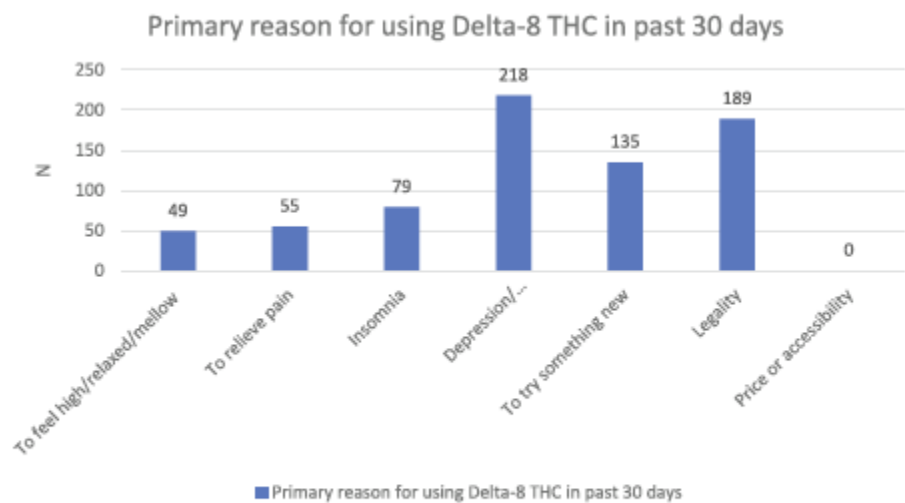
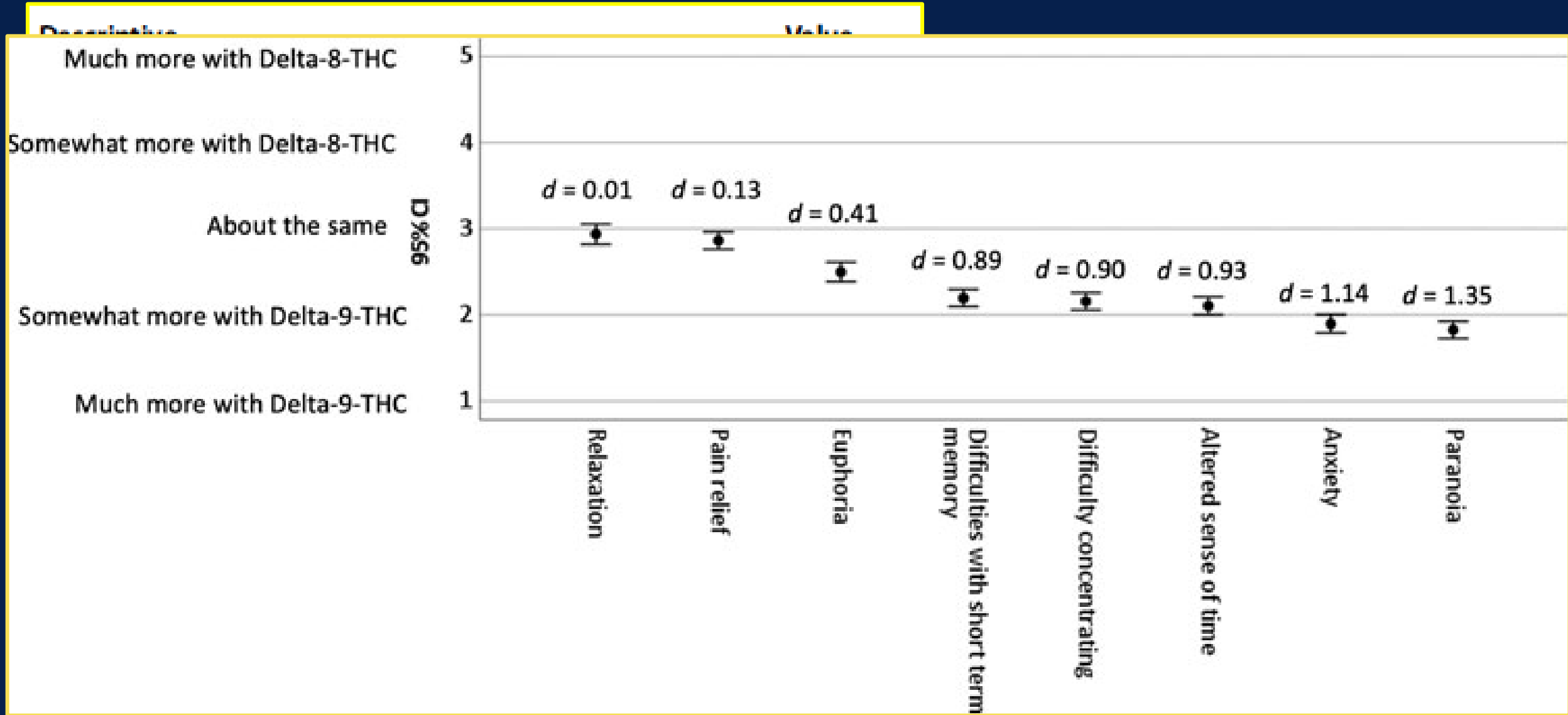

Fig. 1b. Primary reason for using Delta-8 THC among past 30-day Delta-8 THC users (N = 725).

	Delta-8 users (N = 725)	Cannabis-only users (N = 3,623)
	%	
Sociodemographic characteristics		
Gender		
Male	41.4	34.0
Female	51.6	61.7
Other ^b	7.0	4.3
Age (years)		
18–29	42.6	31.2
30–44	27.5	26.9
45–64	27.9	33.7
≥65	2.07	8.2
Race/Ethnicity		
African American	3.2	3.2
American Indian/Alaska Native	0.8	1.5
Asian/Native Hawaiian/Pacific Islander	1.0	1.0
White	79.0	80.4
Hispanic	4.1	3.8
Other	1.8	1.8
Multiracial ^c	10.1	8.3
Employment status		
Employed (Full/Part time)	59.7	54.8
Not employed ^d	40.3	45.2
Educational level		
No high school completion	1.9	2.2
Completed high school or GED	49.7	46.3
Completed college ^e	48.4	51.5



Suppositories
Other

Received: 2021.06.07

Accepted: 2021.10.06

Available online: 2021.11.03

Published: 2021.11.11

Sedation and Acute Encephalopathy in a Pediatric Patient Following Ingestion of Delta-8-Tetrahydrocannabinol Gummies

Authors' Contribution:

Study Design A

Data Collection B

Statistical Analysis C

Data Interpretation D

Manuscript Preparation E

Literature Search F

Funds Collection G

ABCDEF 1 Peter Akpunonu

ABCDEF 2 Regan A. Baum

ABCDEF 3 Andrew Reckers

ABCDEF 1 Blake Davidson

ABCDEF 3 Ross Ellison

ABCDEF 1 Matthew Riley

ABCDEF 4 Jordan Trecki

ABCDEF 3 Roy Gerona

1 Department of Emergency Medicine, University of Kentucky, Lexington, KY, USA

2 Department of Pharmacy Services, University of Kentucky Healthcare, Lexington, KY, USA

3 Clinical Toxicology and Environmental Biomonitoring Lab, UUniversity of California San Francisco (UCSF), San Francisco, CA, USA

4 Diversion Control Division, Drug & Chemical Evaluation Section, Drug Enforcement Administration, Arlington, VA, USA

CDC Health Advisory

September 14, 2021

Several factors can influence both the type and severity of cannabis-related adverse events, including the type of cannabinoid ingested, concentration, route of exposure, and the individual characteristics of the person who consumed the cannabinoid such as their age, weight, and sex. Delta-8 THC intoxication can cause adverse effects similar to those observed during delta-9 THC intoxication^{10,12}, and may include—

- Lethargy
- Uncoordinated movements and decreased psychomotor activity
- Slurred speech
- Increased heart rate progressing to slowed heart rate
- Low blood pressure
- Difficulty breathing
- Sedation
- Coma

CLINICAL COMMUNICATION TO THE EDITOR

THE AMERICAN
JOURNAL *of*
MEDICINE®

Cannabinoid Hyperemesis Syndrome Secondary to Delta-8 THC Use



CrossMark

now increased given this history, she was treated with topical capsaicin cream and 5 mg haloperidol IV with near immediate relief of symptoms. Within an hour, she was able to tolerate medicine by mouth and was discharged after recommending cessation of cannabis use. Electronic medi-

Δ^{10} -tetrahydrocannabinol (Δ^{10} -THC)

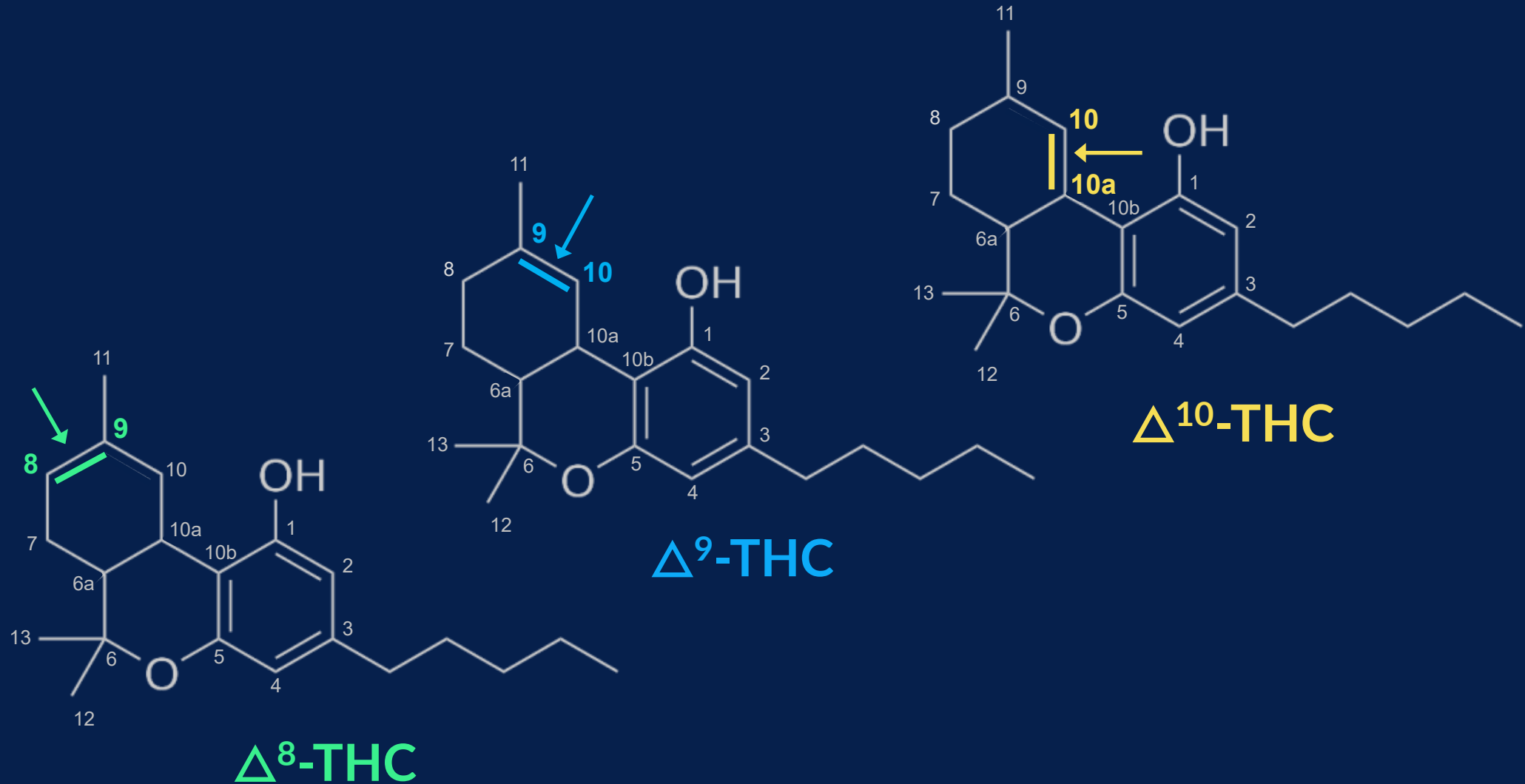

Delta-10-THC

- ◆ Trace phytocannabinoid
- ◆ Contaminant during Δ^8 -THC production
- ◆ Subjective experience:
 - ◆ Similar to Δ^9 -THC
 - ◆ Less potent
 - ◆ More energizing
- ◆ Cross-reacts with Δ^9 -THC immunoassays given structural homology

Questions

1. Are delta-8 / delta-10 products clinically different than delta-9 products?
2. What do you think about the legalization of these products?

Agenda

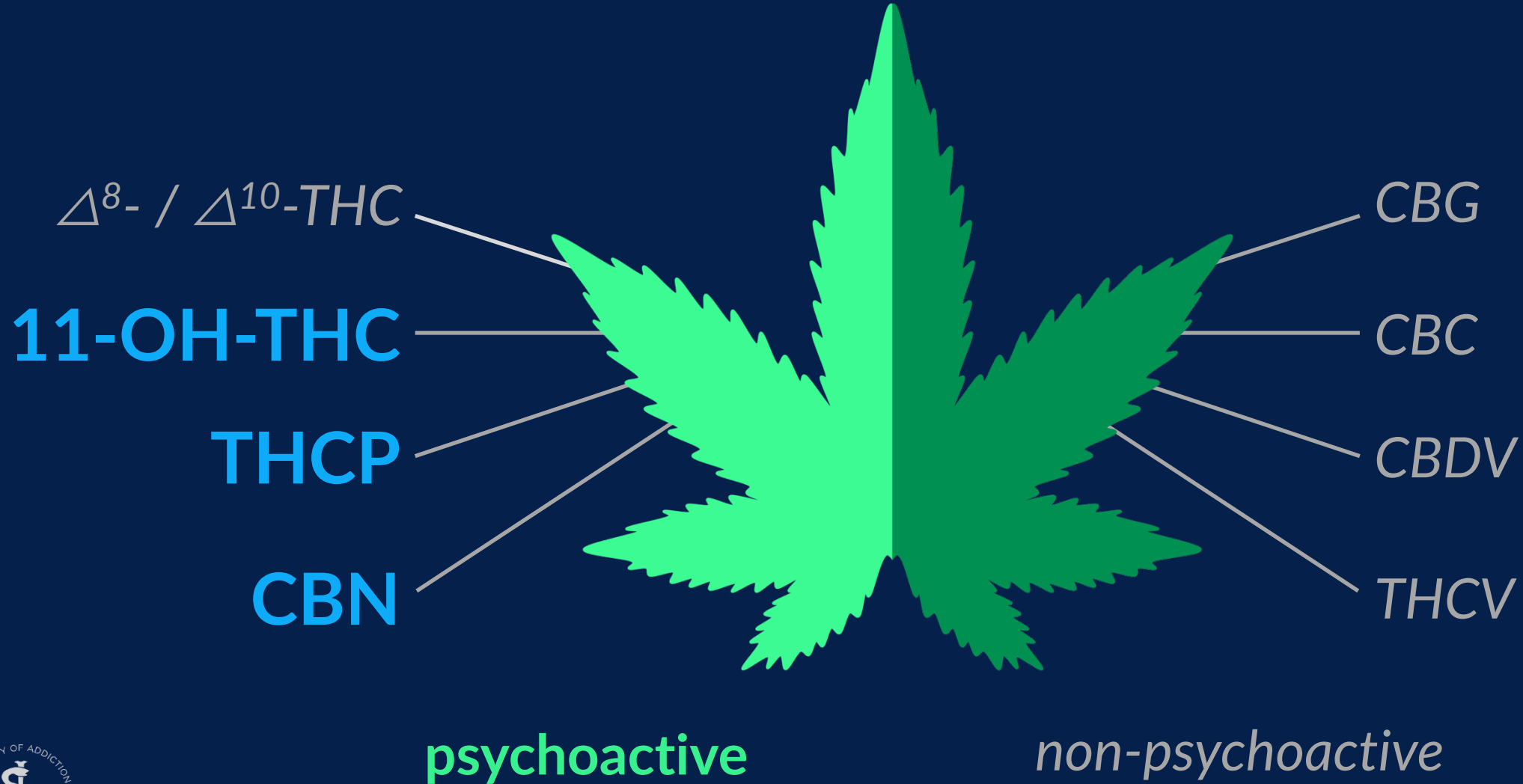

Minor Cannabinoid Pharmacology

- ◆ Current knowledge incomplete
- ◆ Multiple targets: CB1, CB2, 5-HT_{1A}, α_2 receptors, PPAR γ , TRP channels
 - ◆ agonist v. antagonist v. inverse agonist v. partial agonist
 - ◆ properties of side chain impacts affinity for CB1 and CB2

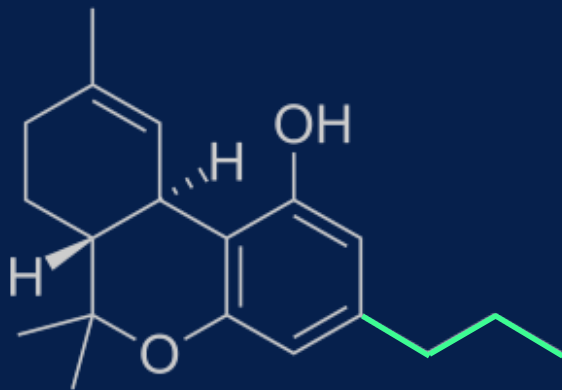

THCV
(tetrahydrocannabivarin)

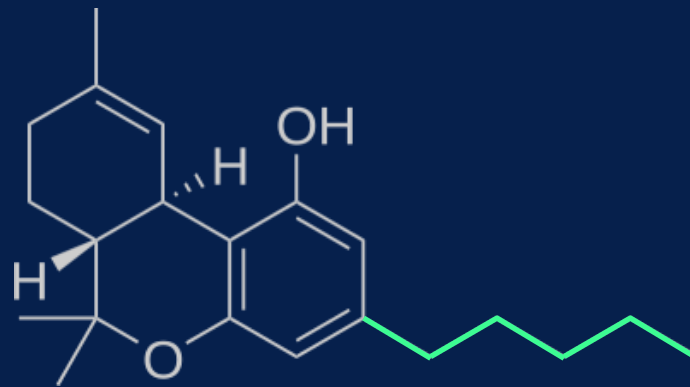

Δ^9 -THC
(Δ^9 -tetrahydrocannabinol)

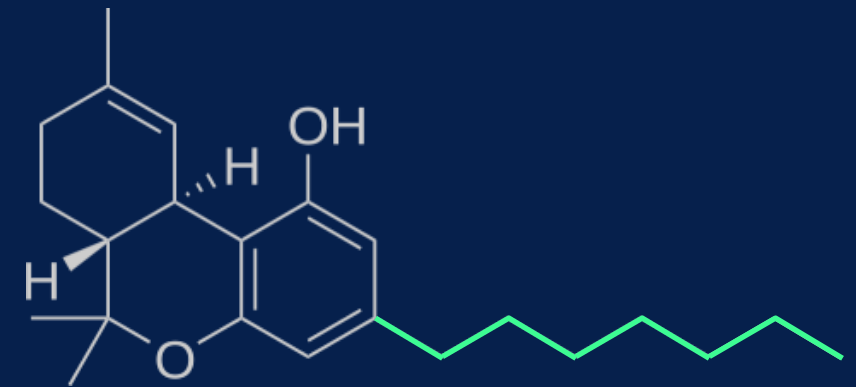

THCP
(tetrahydrocannabiphorol)

11-hydroxy- Δ^9 -tetrahydrocannabinol (11-OH-THC)

- ◆ long-acting active metabolite of Δ^9 -THC
 - ◆ 2x more potent
- ◆ similar PK profile as Δ^9 -THC
 - ◆ consuming THC orally \rightarrow first-pass metabolism via CYP2C9 and 2C19
 - ◆ produces more 11-OH-THC than is generated during inhalational use

Tetrahydrocannabinol (THCP)

Naturally-occurring analog of Δ^9 -THC—a degradation product

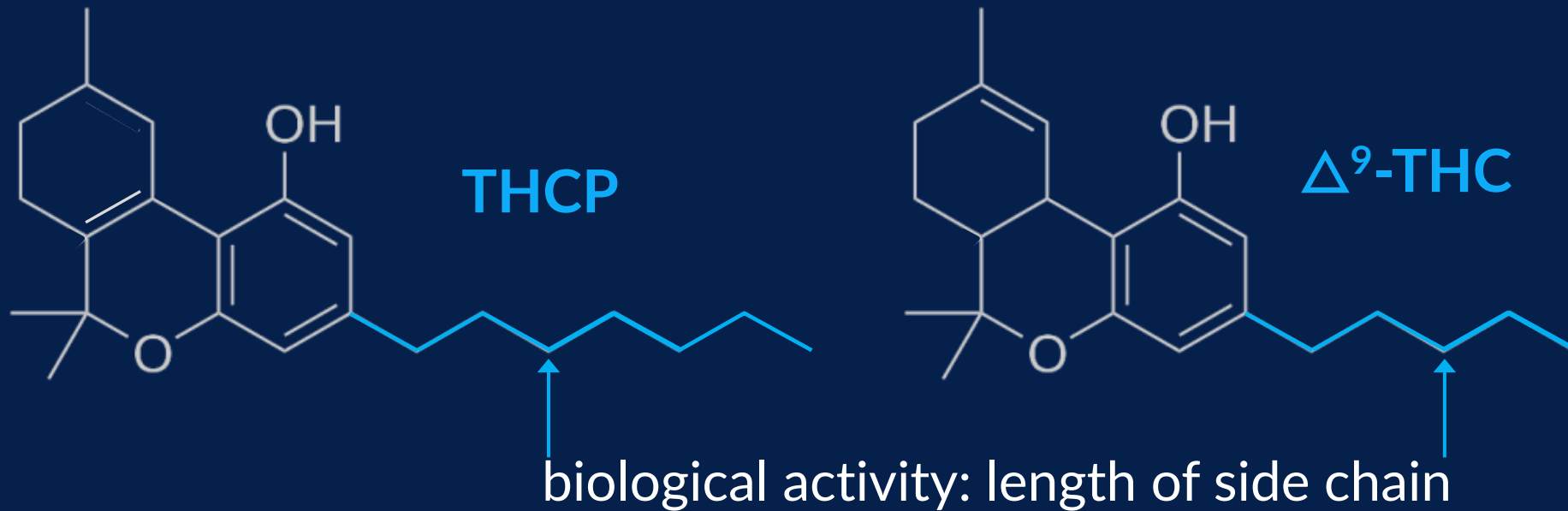

THCP has >30x higher binding affinity for CB1

THCP (aka “Delta 9P”)



THCP – Gummies

\$6.99 – \$19.99 — or subscribe and save up to 35%

Produced in accordance with the 2018 Farm Bill. This product contains both Delta-8 THC and Delta-10 THC.

Using this product may result in a failed drug test. This product is known to have intoxicating effects and may be delayed for by two or more hours. There may be additional health risks with the consumption of this product for women who are pregnant, breastfeeding, or planning to become pregnant. Do not drive or operate heavy machinery while using this product. May cause drowsiness. Keep out of reach of children. This product is not approved by the FDA.

Furthermore, the statements made regarding these products have not been evaluated by the Food and Drug Administration. The efficacy of these products has not been confirmed by FDA-approved research. These products are not intended to diagnose, treat, cure or prevent any disease.

THCP- Gummy Counts

Choose an option

THC-P PRODUCTS

Buy THC-P products online including vape cartridges, disposables, tinctures, and more below.

THC-P is a new legal category that is hemp-derived, Made In The USA, and 100% Natural. THC-P is a lot stronger than other THC cannabinoids, and is not to be confused with Delta 9 THC.



THCP / Delta 9P



Shop ▾ Ingredients ▾ Brands ▾ Strains ▾ Learn ▾

Made in the USA with
American-grown hemp.

Search Products, Categories, and Brands

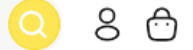

THCP Flower: Taste the Power

[THCP](#) is a new and exciting compound just recently discovered. The cannabinoid can be enjoyed in many different ways, including carts and disposable vapes. However, the most popular way to consume the cannabinoid is through THCP flower. But what exactly is THCP flower? What is the process by which it is made and what should you look for when choosing the right THCP flower?

What is THCP Flower?

THCP flower is hemp flower with added THCP. This product is essentially the same thing you'd buy from a local dispensary or dealer: a smokable flower that produces the same psychoactive effects of cannabis when lit and inhaled. THCP, however, is not just any cannabinoid. It is so potent that its psychoactive level has become the stuff of dreams! But what exactly is THCP? And why has it gained such a reputation?

As of now, THCP, or tetrahydrocannabiphorol, is the strongest, most powerful cannabinoid discovered in cannabis plants. It's an analog of THC which is believed to have about 33 times the potency of regular delta 9. To put things in perspective, delta 9 is twice as powerful as [delta 8](#) and around 30% more powerful than [HHC](#).

Cannabinol (CBN)

- ◆ Naturally occurs in *Cannabis* plants¹—a degradation product
 - ◆ produced when Δ^9 -THC is exposed to light or heat
- ◆ Conflicting reports on CB1/CB2 receptor binding affinity and action (agonist v. partial agonist v. antagonist)^{1,2}
- ◆ Advertised for:
 - ◆ sleep
 - ◆ relaxation
 - ◆ analgesic / anti-inflammatory

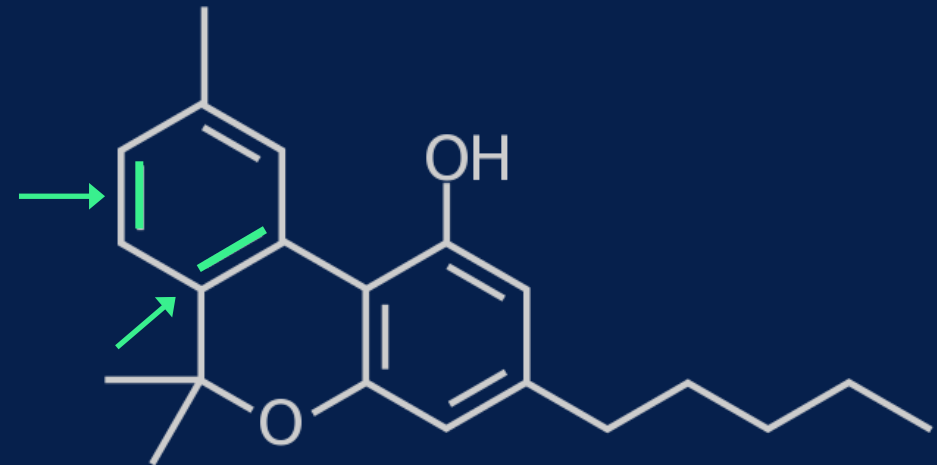

¹Walsh KB, McKinney AE, Holmes AE (Front Pharmacol 2021); ²Sampson PB (J Nat Prod 2021)

Questions

1. Should products that occur in trace amounts in *Cannabis* (like THCP / “Delta 9P”) or as a result of normal THC metabolism (like 11-OH-THC) be regulated in the same manner as Δ^9 -THC?
2. What do you make of the medicinal claims surrounding these products?

Agenda

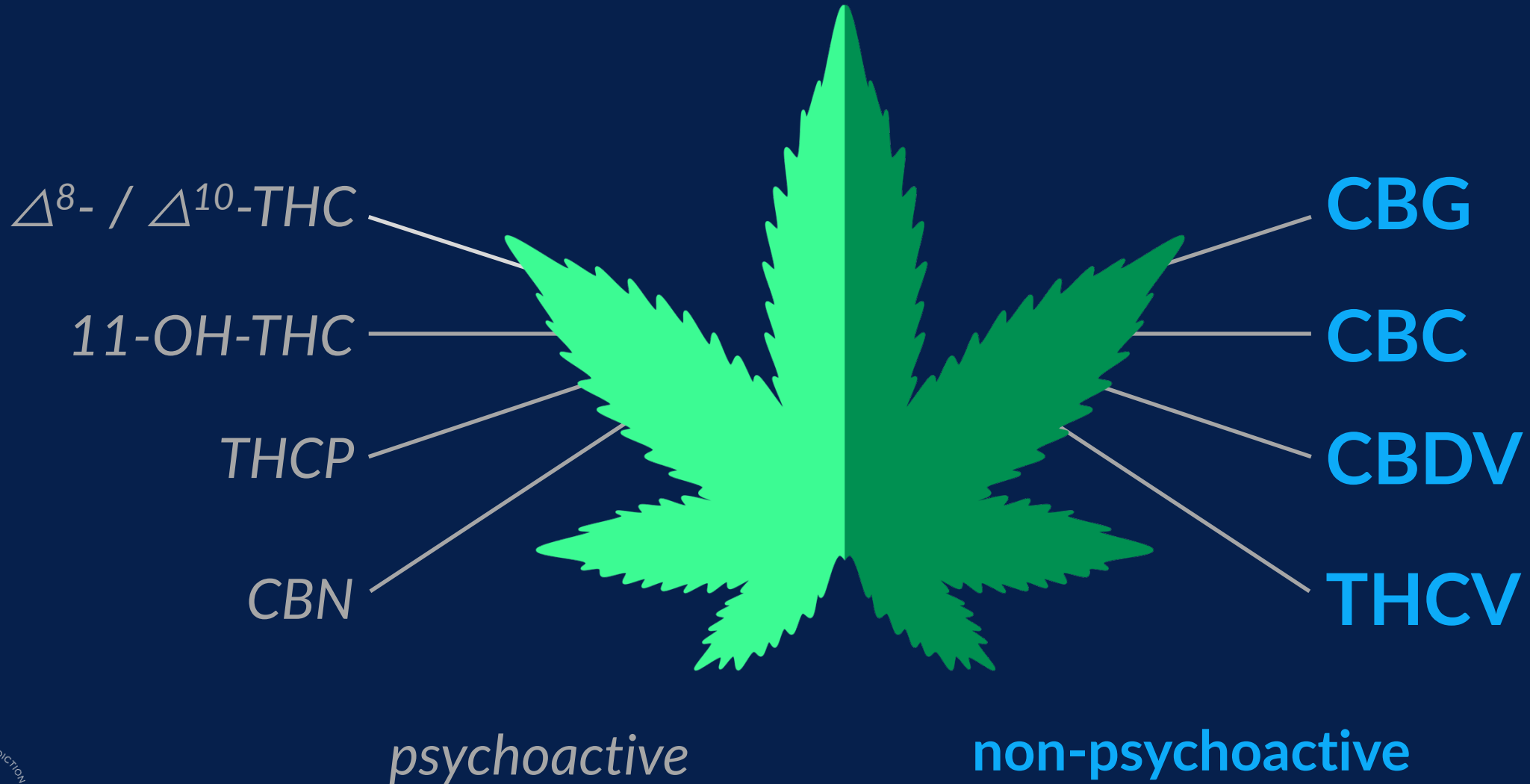

More Structural Analogs

THCV

tetrahydrocannabivarin

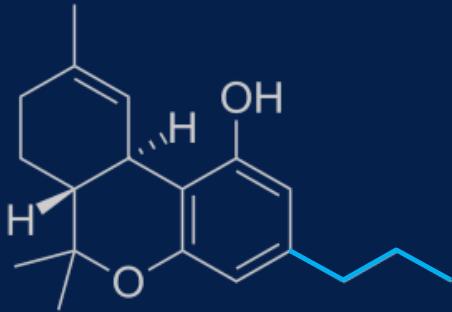

CBDV

cannabidiarin

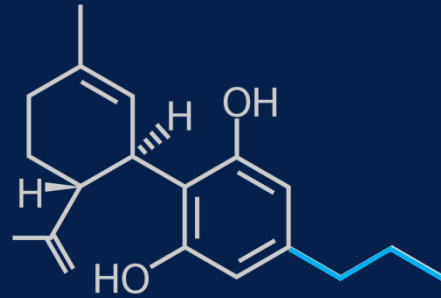

CBC

cannabichromene

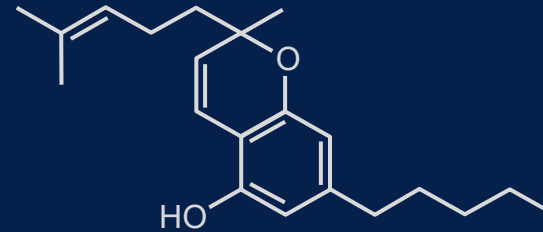

CBG

cannabigerol

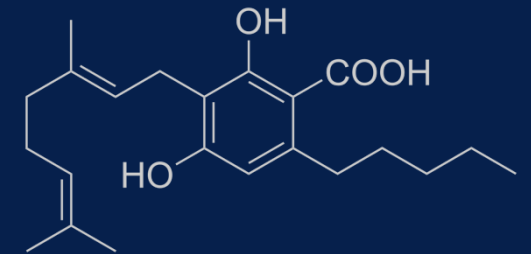

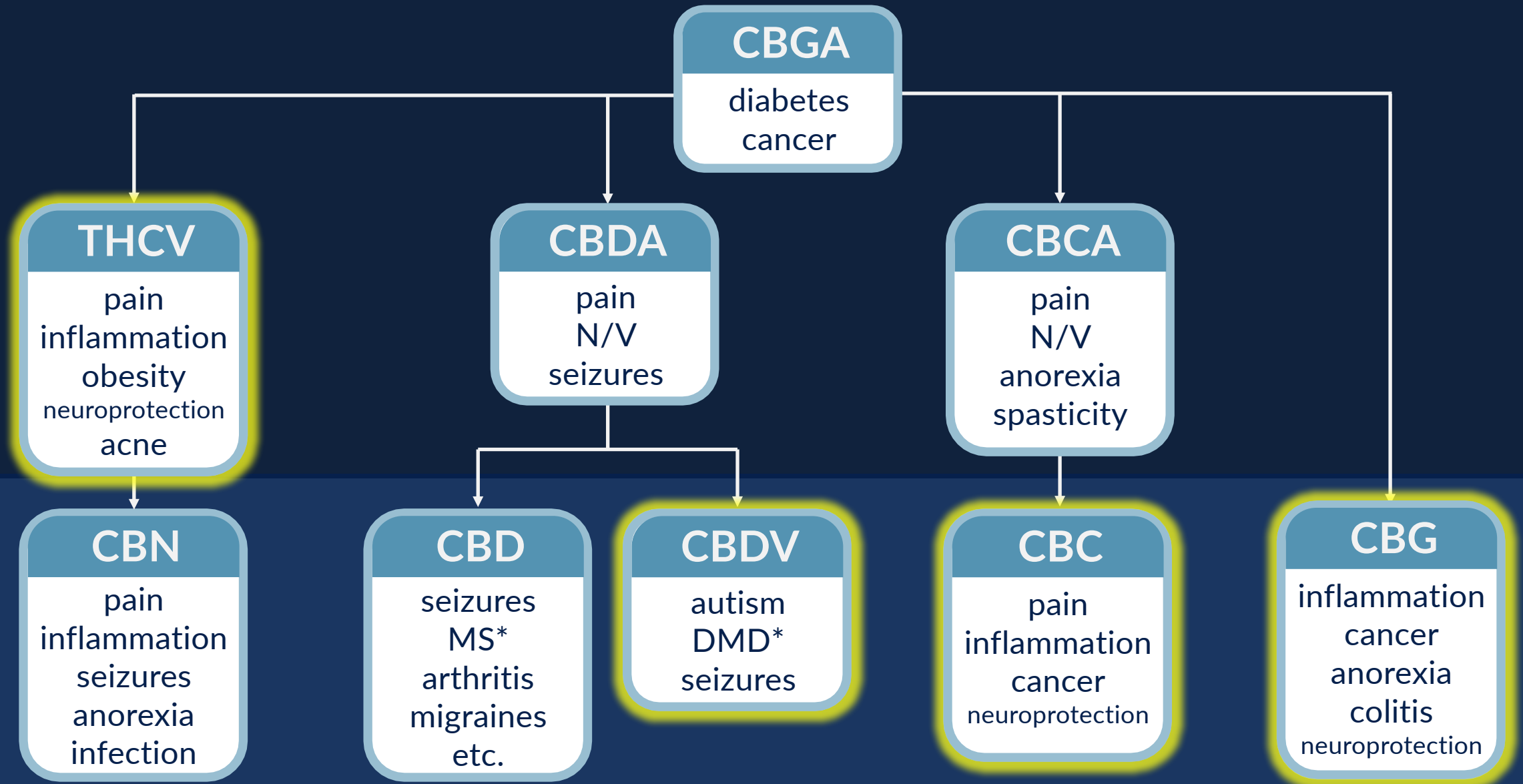

*MS: multiple sclerosis; DMD = Duchenne muscular dystrophy

¹Walsh KB, McKinney AE, Holmes AE (Front Pharmacol 2021)

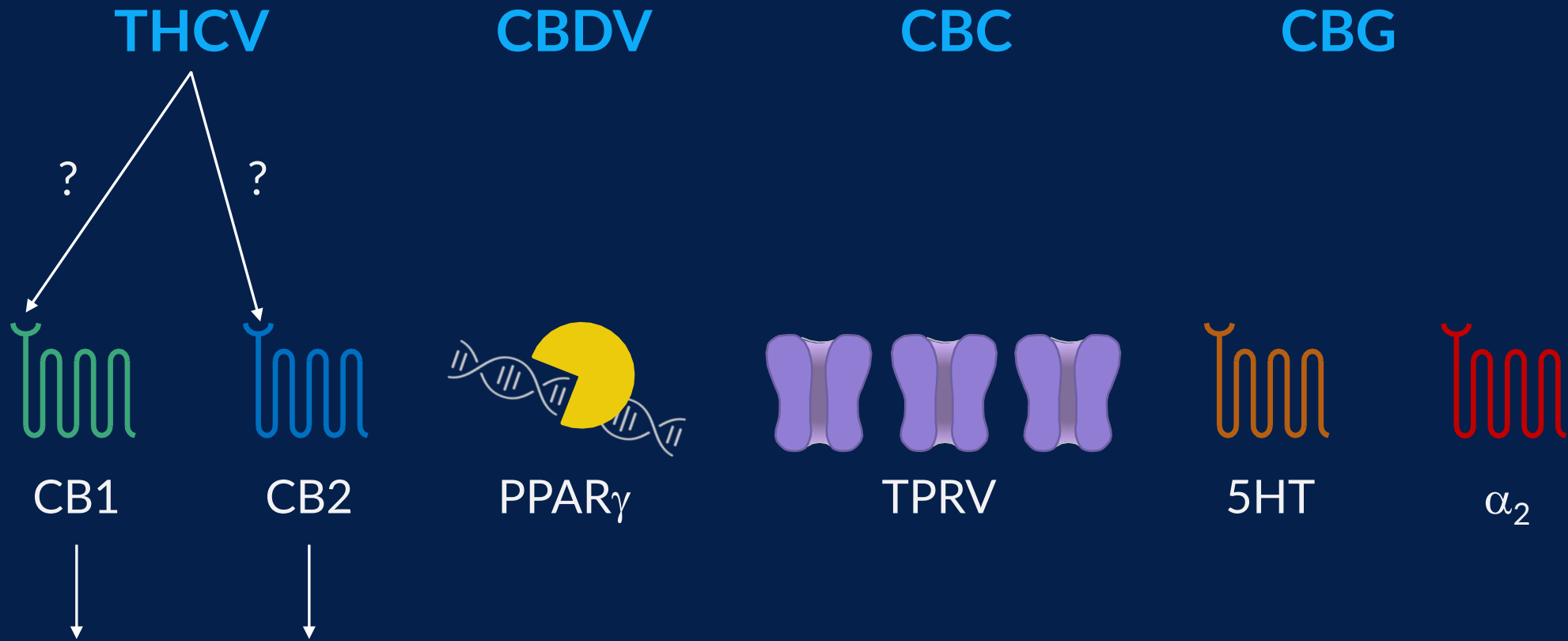

“diet weed”
 appetite suppression, weight loss
 early-stage trials for DM2

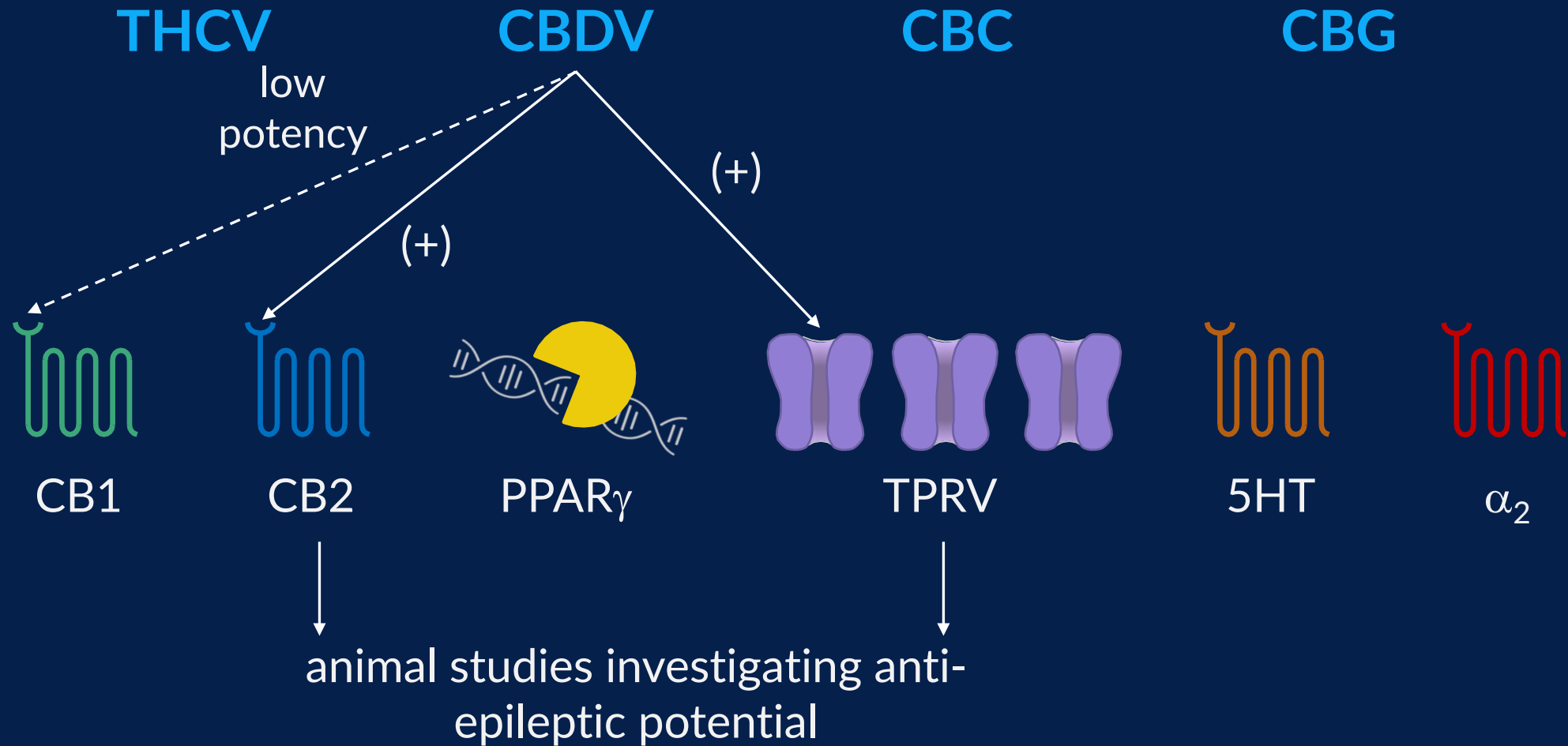

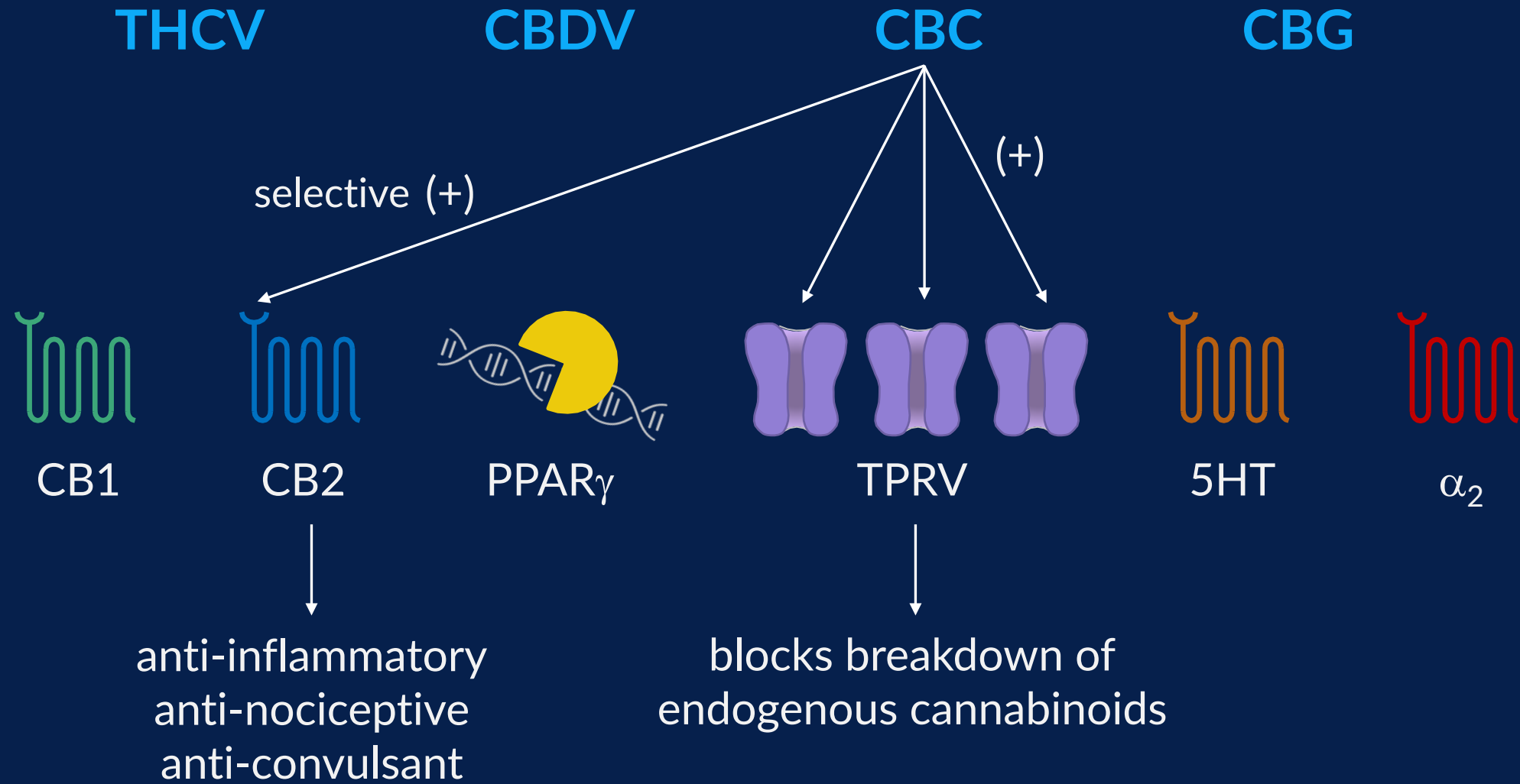

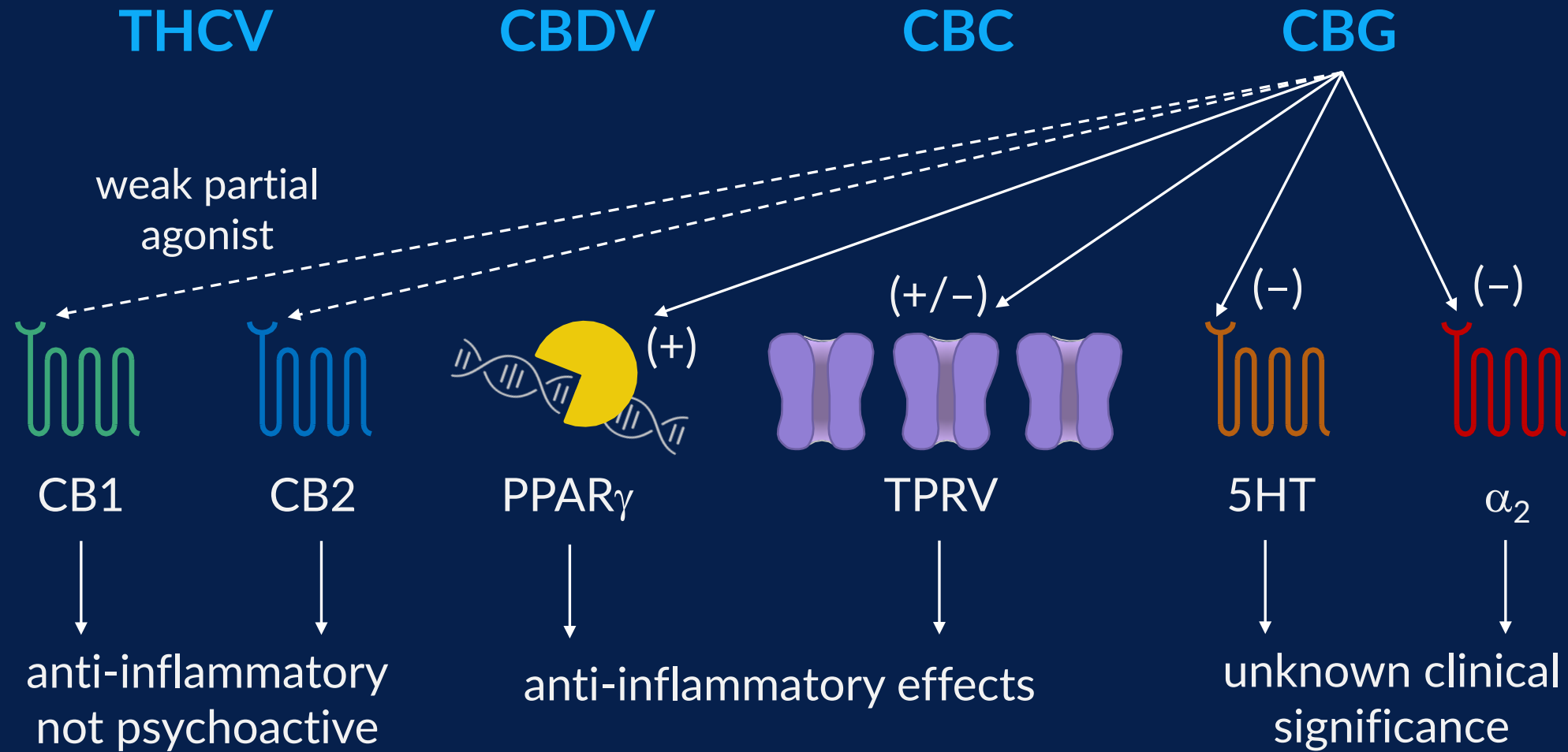

¹Walsh KB, McKinney AE, Holmes AE (Front Pharmacol 2021); ²Sampson PB (J Nat Prod 2021); ³Russo EB, Marcu J (Adv Pharmacol 2017);

⁴Jadoon KA, et al. (Diabetes Care 2016); ⁵Abioye A, et al. (J Cannabis Res 2020); ⁶Udoh M, et al. (Brit J Pharmacol 2019)

Relative Cannabinoid Potency

	CB1	CB2
THC ¹	0.013 – 0.087 mM	0.042 – 0.061 mM
CBN ²	0.12 mM	0.29 mM
CBC ²	0.19 mM	0.007 – >3 mM
THCV ²	0.03 – >10 mM	0.038 – >10 mM

Questions

1. What do you make of the medicinal claims surrounding these products?

Agenda



CBD

psychoactive

non-psychoactive

Cannabidiol (CBD)

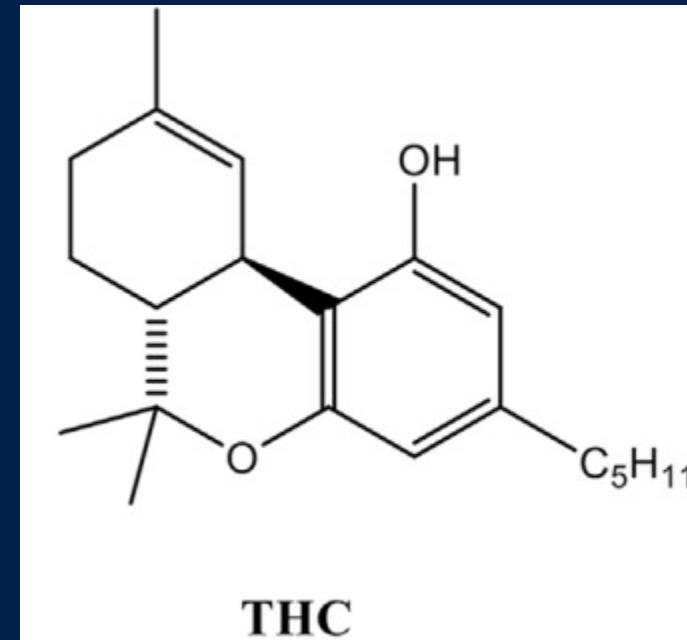
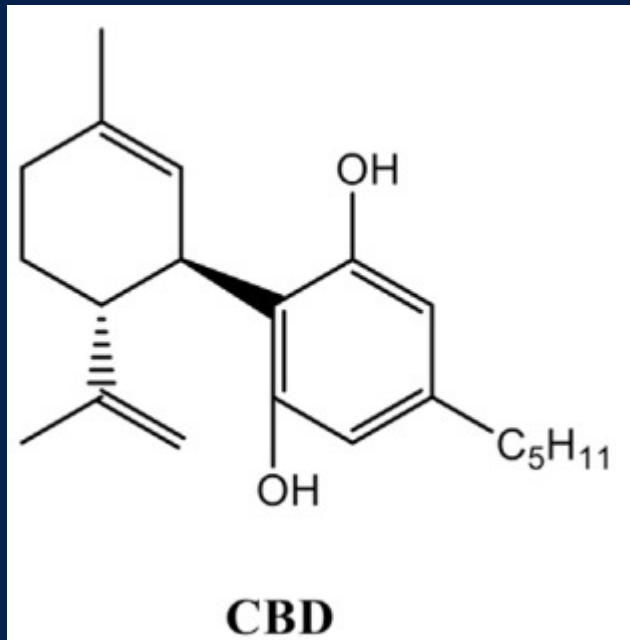

CBD: Products & Industry



CBD Sales in the U.S. Expected to Grow Fast

Consumer sales of cannabidiol products in the U.S. (in million U.S. dollars)

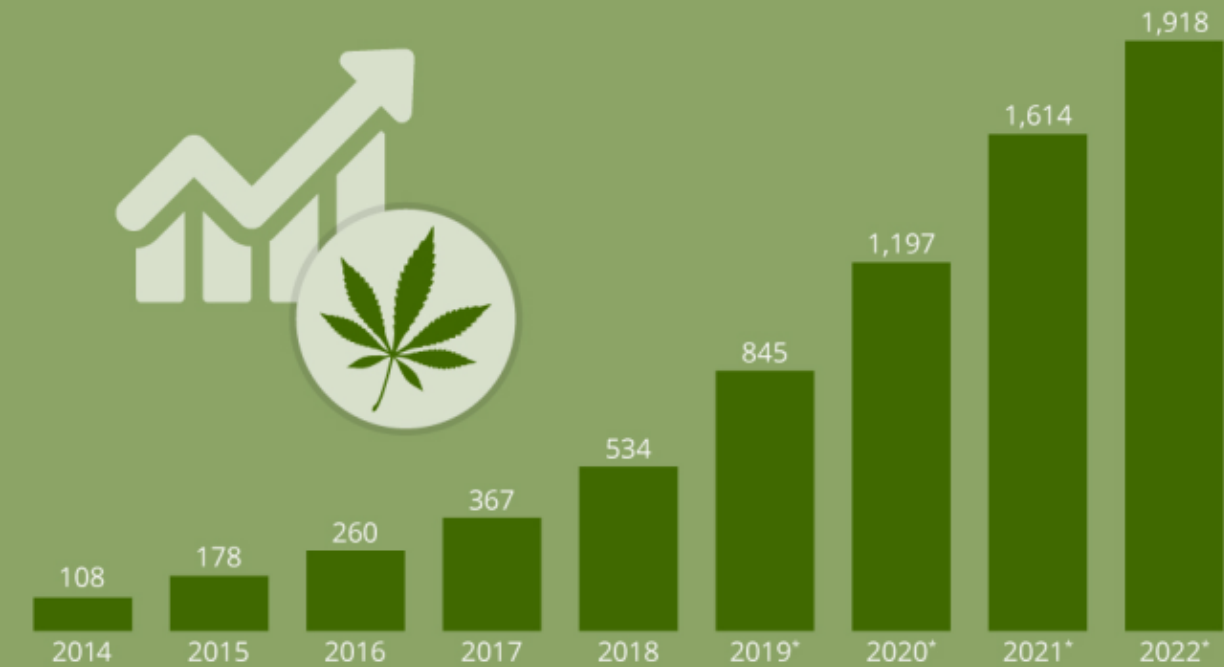

© StatistaCharts

* projected

Source: Hemp Business Journal

statista

Potential Therapeutic Benefits...

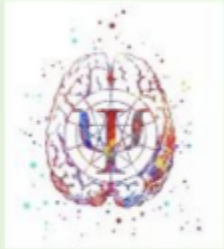

Psychotic



Anxiety



Epilepsy



Sleep



Cardiovascular



Diabetes



Pain

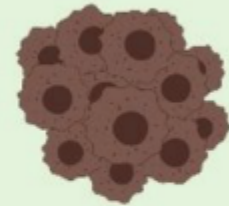

Cancer

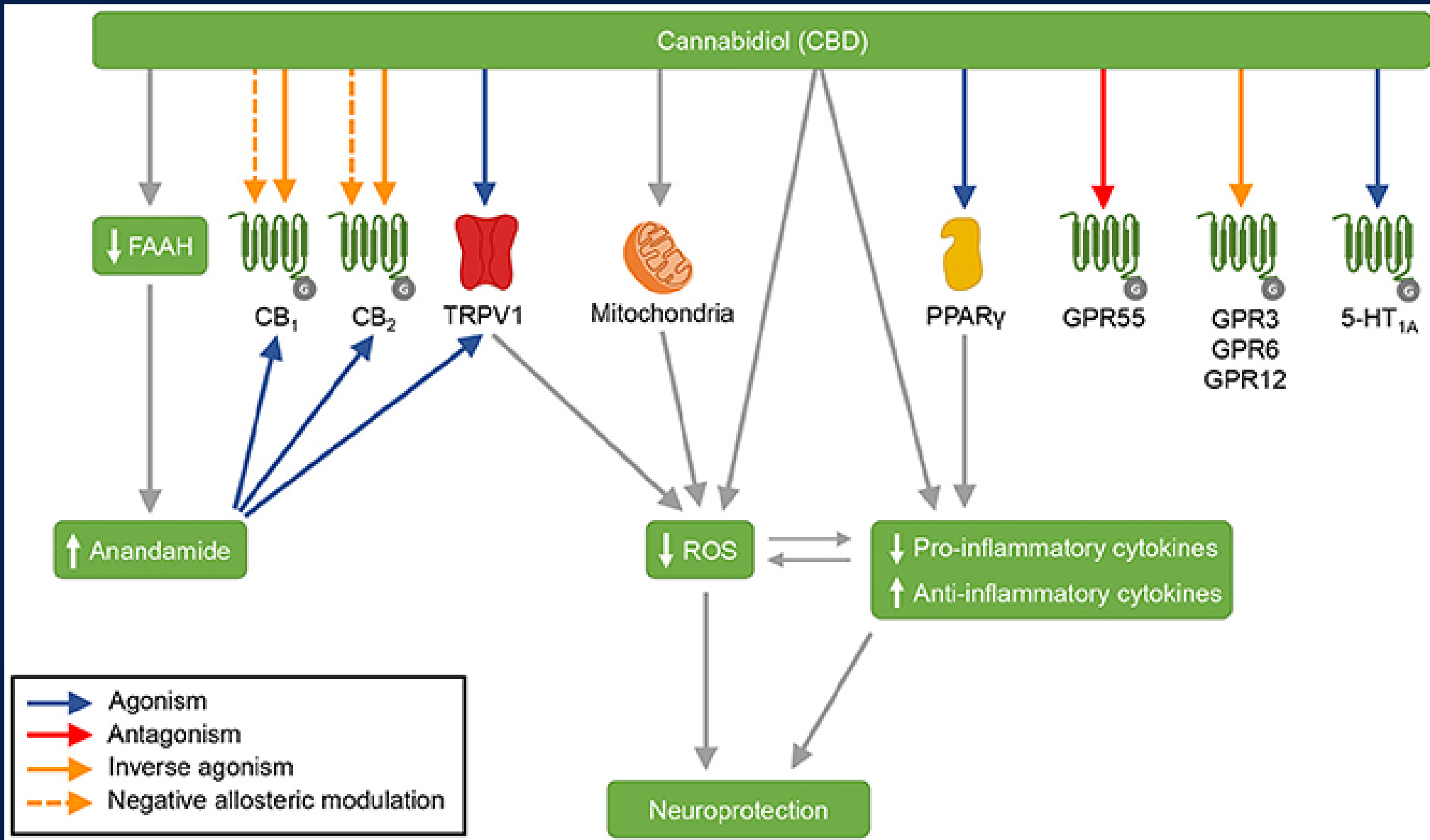

Psychopathological Effects (CBD vs THC)

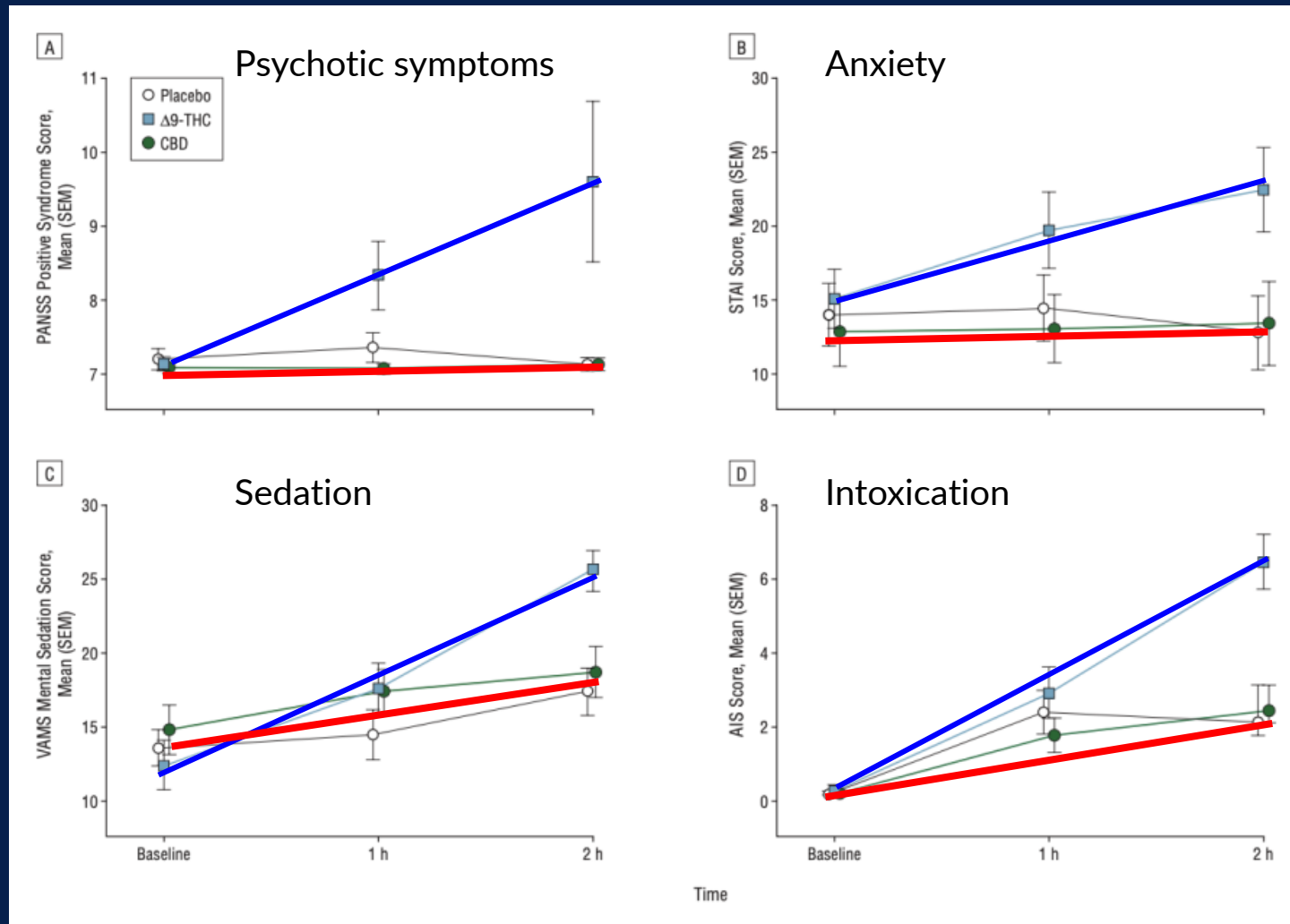

Adverse effects of cannabidiol: a systematic review and meta-analysis of randomized clinical trials

[Edward Chesney](#) , [Dominic Oliver](#), [Alastair Green](#), [Simina Sovi](#), [Jack Wilson](#), [Amir Englund](#), [Tom P. Freeman](#) & [Philip McGuire](#)

12 trials, 803 participants

- Abnormal LFTs (OR 11.19)
- Pneumonia (OR 5.37)
- Sedation (OR 4.21)
- Decreased appetite (OR 3.56)
- Diarrhea (OR 2.61)
- Withdrawal for any reason (OR 2.61)
- Somnolence (OR 2.23)

Update on Cannabidiol Clinical Toxicity and Adverse Effects: a Systematic Review

Author(s): Graziella Madeo, Ashita Kapoor, Raffaele Giorgetti, Francesco Paolo Busardò* and Jeremy Carlier

51 reports, most mild/moderate AEs

- Diarrhea
- Somnolence
- Sedation
- Upper respiratory disturbances
- Few serious AEs from DDI

CBD Toxicity & Testing

- ◆ Generally well tolerated
- ◆ Human CBD studies → mild symptoms
 - ◆ CNS depression
 - ◆ Elevated transaminases
 - ◆ Respiratory disturbances
 - ◆ Diarrhea, nausea, vomiting
 - ◆ CBD-induced drug-drug interactions
- ◆ Metabolism
 - ◆ CYP3A4, 2C19, UGT1A7,1A9,2B7
- ◆ In isolation, CBD does NOT cross react with Δ 9-THC immunoassays
 - ◆ CBD products CAN contain or be contaminated with Δ 9-THC or cannabinol

UDS Cross Reactivity

TOXICOLOGY ROUNDS

Your ED Patients Are Likely Using Delta-8-THC

BY LEON GUSSOW, MD

The Michigan Poison Center issued a warning this past April about delta-8-THC, a little-known cannabinoid found in hemp and marijuana that has replaced cannabidiol (CBD) as the most rapidly growing segment of the unregulated hemp market.

Virtually unknown two years ago, delta-8-THC can now be purchased over the counter in many vape and smoke shops, gas stations, and con-

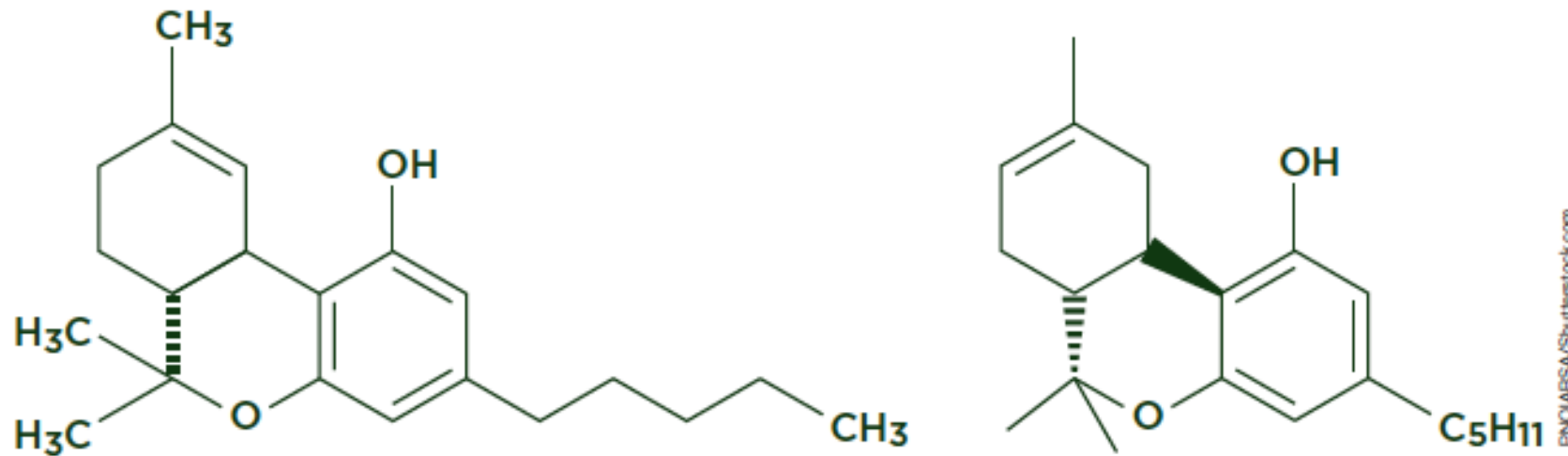

Delta-8-tetrahydrocannabinol, left, and delta-9-tetrahydrocannabinol are similar except for the location of the double bond.

PNCIAPSA/Shutterstock.com

Concerns

- ◆ Unknown safety profiles—not rigorously tested or studied in humans¹
- ◆ Pediatric exposures¹
- ◆ Unknown amounts
 - ◆ 84 CBD products available online²
 - ◆ 26% contained less CBD than indicated (>10% deviation from label)
 - ◆ 43% contained more CBD than indicated
 - ◆ 31% accurately labeled
 - ◆ 20 CBD products in Mississippi³
 - ◆ 2 of 20 were within 10% of the advertised CBD content
- ◆ Contamination with microbes, pesticides, etc.¹



¹National Center for Complementary and Integrative Health, National Institutes of Health, 2019; ²Bonn-Miller MO, et al. (JAMA 2017);

³Gurley BJ, et al. (J Dietary Suppl 2020)

Questions

A provider with SUD is being monitored by the state medical board and starts taking CBD capsules for anxiety. The next random UDS immunoassay shows the presence Δ^9 -THC.

- ◆ Is this UDS result expected?
- ◆ Can we differentiate Δ^9 -THC from CBD use on a UDS?
- ◆ Can we differentiate Δ^9 -THC from CBD use clinically?



Societal Issues & Policy Implications

- ◆ Cannabis potency increasing over past 4 decades
 - ◆ substance-induced psychosis
 - ◆ unmasking genetic predisposition for primary psychotic disorder
- ◆ Decriminalization: harm vs harm reduction
 - ◆ effects on opioid use
 - ◆ driving / operating machinery
- ◆ Medicalization (dispensaries)
- ◆ Regulatory issues:
 - ◆ CBD product content, marketing, contaminants
- ◆ Environmental sustainability
- ◆ Vulnerable populations
 - ◆ substance induced psychosis / unmasking a genetic predisposition
 - ◆ effects on developing brain

Final Takeaways

- ◆ An unintended consequence of the 2018 Farm Bill was the commercialization of novel (aka minor) cannabinoids
- ◆ These novel cannabinoids are present in very low concentrations in cannabis plants
- ◆ Many minor cannabinoids have similar effects to Δ^9 -THC
- ◆ Minor cannabinoids may cross-react with Δ^9 -THC on immunoassay drug screens

MARIHUANA

THE BURNING WEED
WITH ITS ROOTS IN

Well

!

A PUFF
OF SMOKE
STARTED
HER ON
HER WAY

!

AMERICA'S
NEWEST
NARCOTIC
MENACE



References

1. Abioye A, Ayodele O, Marinkovic A, Patidar R, Akinwekomi A, Sanyaolu A. Δ 9-Tetrahydrocannabivarin (THCV): a commentary on potential therapeutic benefit for the management of obesity and diabetes. *J Cannabis Res*. 2020;2(1):6. doi:10.1186/s42238-020-0016-7.
2. Akpunonu P, et al. Sedation and acute encephalopathy in a pediatric patient following ingestion of delta-8-tetrahydrocannabinol gummies. *Am J Case Rep* 2021;22:e933488.
3. An D, Peigneur S, Hendrickx LA, Tytgat J. Targeting cannabinoid receptors: Current status and prospects of natural products. *International Journal of Molecular Sciences*, 2020; 21: 5064. doi: 10.3390/ijms21145064.
4. Babalonis S, et al. Delta 8-THC: Legal Status, Widespread Availability, and Safety Concerns. *Cannabis Cannabinoid Res* 201;6(5):362-5.
5. Bonn-Miller MO, Loflin MJE, Thomas BF, Marcu JP, Hyke T, Vandrey R. Labeling accuracy of cannabidiol extracts sold online. *JAMA*. 2017;318(17):1708–9. <https://doi.org/10.1001/jama.2017.11909>.
6. Chesney E, Oliver D, Green A, et al. Adverse effects of cannabidiol: a systematic review and meta-analysis of randomized clinical trials. *Neuropsychopharmacology*. 2020;45(11):1799-1806. doi:10.1038/s41386-020-0667-2.
7. Citti C, et al. A novel phytocannabinoid isolated from *Cannabis sativa* L with an in vivo cannabimimetic activity higher than delta 9-THC: delta -THC. *Sci Rep* 2019;9:20335.
8. Fusar-Poli P, Crippa JA, Bhattacharyya S, Borgwardt SJ, Allen P, Martin-Santos R, Seal M, Surguladze SA, O'Carroll C, Atakan Z, Zuardi AW, McGuire PK. Distinct effects of {delta}9-tetrahydrocannabinol and cannabidiol on neural activation during emotional processing. *Arch Gen Psychiatry*. 2009;66(1):95-105.

References

9. Grinspoon P. Beyond CBD: here come the other cannabinoids, but where's the evidence? Harvard Health Blog. March 23, 2021. <https://www.health.harvard.edu/blog/beyond-cbd-here-come-the-other-cannabinoids-but-wheres-the-evidence-2021032322190>.
10. Gurley BJ, Murphy TP, Gul W, Walker LA, El-Sohly M. Content versus label claims in cannabidiol (CBD)-containing products obtained from commercial outlets in the state of Mississippi. *J Dietary Suppl.* 2020;17(5):599–607. <https://doi.org/10.1080/19390211.2020.1766634>.
11. Hanuš LO, Meyer SM, Muñoz E, Tagliabatella-Scafati O, Appendino G. Phytocannabinoids: a unified critical inventory. *Nat Prod Rep.* 2016;33(12):1357-1392.
12. Haroutounian S, Gilron I, Belton J, Degenhardt L, Di Forti M, Finn DP, Fogarty A, Kalso E, Krane E, Moore RA, Rowbotham M, Wallace M, Rice ASC. Societal issues and policy implications related to the use of cannabinoids, cannabis, and cannabis-based medicines for pain management. *Pain.* 2021 Jul 1;162(Suppl 1):S110-S116. doi: 10.1097/j.pain.0000000000002001. PMID: 33009248.
13. Huestis MA, Solimini R, Pichini S, Pacifici R, Carlier J, Busardò FP. Cannabidiol Adverse Effects and Toxicity. *Curr Neuropharmacol.* 2019;17(10):974-989.
14. Jadoon, K.A., Ratcliffe, S.H., Barrett, D.A., Thomas, E.L., Stott, C., Bell, J.D., O'Sullivan S.E. and Tan, G.D. 2016. Efficacy and Safety of Cannabidiol and Tetrahydrocannabivarin on Glycemic and Lipid Parameters in Patients With Type 2 Diabetes: A Randomized, Double-Blind, Placebo-Controlled, Parallel Group Pilot Study. *Diabetes Care.* 39 (10), pp. 1777-1786. <https://doi.org/10.2337/dc16-0650>.

References

15. Klumpers LE, Thacker DL. A brief background on cannabis: from plant to medical indications. *J AOAC*. 2019;102(2):412-420.
16. Kroner GM, Johnson-Davis KL, Doyle K, McMillin GA. Cannabinol (CBN) Cross-React with Two Urine Immunoassays Designed to Detect Tetrahydrocannabinol (THC) Metabolite, *The Journal of Applied Laboratory Medicine*, Volume 5, Issue 3, May 2020, Pages 569–574, <https://doi.org/10.1093/jalm/jfaa020>.
17. Kruger D. *Cannabis and Cannabinoid Research* 2023;8:166-73.
18. Landmark CJ, Brandl U. Pharmacology and drug interactions of cannabinoids. *Epileptic Disord*. 2020;22(S1):16-22. doi:10.1684/epd.2019.1123\2017;318(17):1708–1709. doi:10.1001/jama.2017.11909.
19. Lemberger L, Crabtree RE, Rowe HM. 11-Hydroxy- Δ^9 -tetrahydrocannabinol: Pharmacology, disposition, and metabolism of a major metabolite of marijuana in man. *Science*. 1972;177(4043):62-64.
20. Livne O, et al. Delta-8 THC use in US adults: Sociodemographic characteristics and correlates. *Addict Behav* 2022;133:107374.
21. Madeo G, Kapoor A, Giorgetti R, Busardò FP, Carlier J. Update on Cannabidiol Clinical Toxicity and Adverse Effects: a Systematic Review [published online ahead of print, 2023 Mar 22]. *Curr Neuropharmacol*. 2023;10.2174/1570159X21666230322143401. doi:10.2174/1570159X21666230322143401.
22. Nachnani R, Raup-Konsavage WM, Vrana KE. The pharmacological case for cannabigerol. *J Pharmacol Exp Ther*. 2021;376(2):204-212. doi:10.1124/jpet.120.000340.
23. Peres FF, Lima AC, Hallak JEC, Crippa JA, Silva RH, Abílio VC. Cannabidiol as a Promising Strategy to Treat and Prevent Movement Disorders? *Front Pharmacol*. 2018;9:482.

References

24. Peng J, Fan M, An C, Ni F, Huang W, Luo J. A narrative review of molecular mechanism and therapeutic effect of cannabidiol (CBD). *Basic Clin Pharmacol Toxicol*. 2022;130(4):439-456.
25. Rosenthal J. *American Journal of Medicine* 2021;134(12):e582-3.
26. Russo EB, Marcu J. Cannabis pharmacology: The usual suspects and a few promising leads. *Adv Pharmacol*. 2017;80:67-134.
27. Sampson PB. Phytocannabinoid pharmacology: Medicinal properties of Cannabis sativa constituents aside from the “Big Two.” *Journal of Natural Products*, 2021; 84(1):142-160. doi: 10.1021/acs.jnatprod.0c00965.
28. Udoh M, Santiago M, Devenish S, McGregor IS, Connor M. Cannabichromene is a cannabinoid CB₂ receptor agonist. *British Journal of Pharmacology* (2019): 176(23):4537-4547. doi: 10.1111/bph.14815.
29. Walsh KB, McKinney AE, Holmes AE. Minor Cannabinoids: Biosynthesis, Molecular Pharmacology and Potential Therapeutic Uses. *Frontiers in Pharmacology*, 2021; 12:1-18. doi: 10.3389/fphar.2021.777804.

Online References

- <https://www.nccih.nih.gov/health/cannabis-marijuana-and-cannabinoids-what-you-need-to-know>. Updated November 2019. Accessed 02/23/2023.
- <https://www.thegreendragoncbd.com/>
- <https://learn.uvm.edu/blog/blog-health/cannabis-faculty-member-publishes-comprehensive-report-on-delta-8-thc>
- <https://www.fda.gov/news-events/press-announcements/fda-issues-warning-letters-companies-illegally-selling-cbd-and-delta-8-thc-products>
- <https://mogreenway.com/2022/01/08/the-legal-challenges-of-delta-8-thc/>
- <https://kindmedsaz.com/blog/what-is-delta-8/>
- <https://vitalitycbd.com/hhc-vs-delta-8-what-is-difference/>
- <https://blog.lunatechequipment.com/delta-8-vs-delta-9>
- Emergency Medicine News (August 2021)
- Wikipedia: THCP and THC pages